



Item No. _____

H60

Shake Freezer

Four Flavor

Features

Offer four separate shake flavors: chocolate, strawberry, vanilla (unflavored shake mix) and an optional flavor.

Heat Treatment System

Provides a daily heating and cooling cycle to safely maintain dairy products up to two weeks before a complete disassembly and cleaning is required.

Freezing Cylinder

One, 7 quart (6.6 liter).

Mix Hopper

One, 20 quart (18.9 liter). Refrigerated to maintain mix below 41°F (5°C).

Indicator Lights

Mix Low light alerts the operator to add mix. When the Mix Out light flashes, the unit automatically goes into Standby mode to prevent damage.

Electronic Controls

Viscosity is continually measured to serve consistent quality shakes. The LCD (Liquid Crystal Display) readout will identify temperatures in the hopper or freezing cylinder at any point of operation. History of temperatures and times during the last 13 heat cycles may be viewed.

Standby

During long no-use periods, the standby feature maintains safe product temperatures in the mix hopper and freezing cylinder.

Shake Syrup System

Shake flavors are selected from touch pads. Self-contained air compressor delivers shake syrup from three, 1 gallon (3.8 liter) syrup tanks located in the lower front compartment. Use only single strength syrup, free from pulp and seeds.

Automatic Dispensing

Press the desired flavor and raise the draw handle. Frozen shake mix and syrup automatically blends to dispense the chosen flavor. After the shake is drawn, press the Rinse touch pad to eliminate flavor carryover. Rinse water connection under side of base is 3/8" FPT.

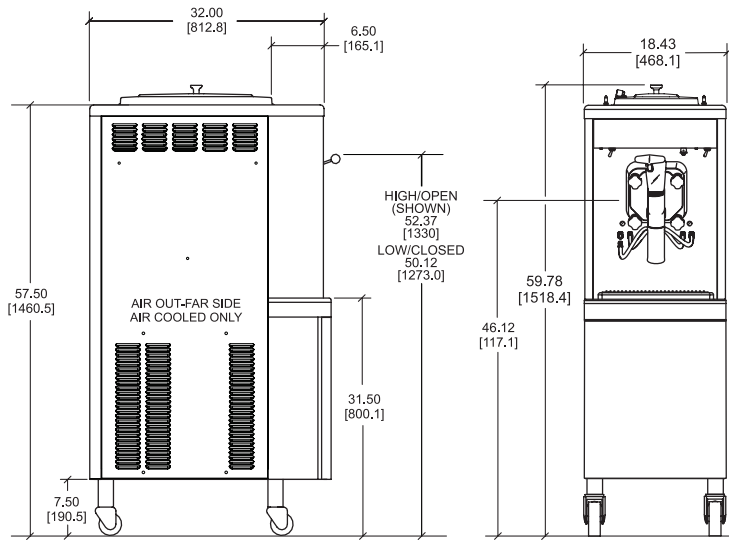

FIGURES IN BRACKETS INDICATE MILLIMETERS. DIMENSIONS EQUAL TO PLUS OR MINUS 1/16 inch [1.57mm].

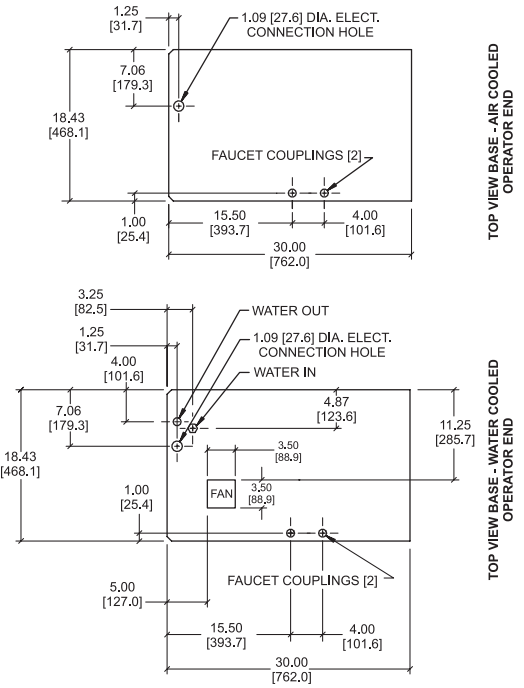

Weights	lbs.	kgs.
Net	544	246.7
Crated	557	252.7
Volume	cu. ft.	cu. m.
	36.1	1.02
Dimensions	in.	mm.
Width	18-7/16	468
Depth	32	813
Height	59-7/8	1519
Floor Clearance	7-1/2	191

*Mounted on standard casters

Electrical	Maximum	Minimum	Poles (P)
	Fuse Size	Circuit Ampacity	
208-230/60/1 Air	30	23	2P 3W
208-230/60/1 Water	35	22	2P 3W
208-230/60/3 Air	25	17	3P 4W
208-230/60/3 Water	25	17	3P 4W
220-240/50/1 Air	30	20	2P 3W
380-415/50/3N~ Air	15	15	4P 5W

This unit may be manufactured in other electrical characteristics and may have additional regulatory agency approvals. Consult the local Taylor Distributor for other electrical characteristics and agency approvals based on specific electrical and country requirements.

(For exact electrical information and approval marks, always refer to the data label of the unit.)

Continuing research results in steady improvements; therefore, these specifications are subject to change without notice.

Bidding Specs

Electrical: Volt _____ Hz _____ ph _____
 Neutral: Yes No **Cooling:** Air Water NA

Options: _____

Authorized Taylor Distributor

Specifications

Electrical

One dedicated electrical connection is required. See the Electrical chart for the proper electrical requirements. Manufactured to be permanently connected. Consult your local Taylor distributor for cord & receptacle specifications as local codes allow.

Beater Motor

One, 1.0 HP

Refrigeration System

One, 11,000 BTU/hr. R404A.
 (BTUs may vary depending on compressor used.)

Air Cooled

Minimum Clearance: 6" (152 mm) on all sides. Minimum air clearances must be met to assure adequate air flow for optimum performance.

Water Cooled

Water inlet and drain connections under side of base 3/8" FPT.

Options

- Hopper Locks



750 N. Blackhawk Blvd.
 Rockton, Illinois 61072
www.taylor-company.com