

Model C707

Soft Serve Freezer

Original Operating Instructions

059060-M



**May, 2003 (Original Publication)
(Updated September, 2011)**

Complete this page for quick reference when service is required:

Taylor Distributor: _____

Address: _____

Phone: _____

Service: _____

Parts: _____

Date of Installation: _____

Information found on the data label:

Model Number: _____

Serial Number: _____

Electrical Specs: Voltage _____ Cycle _____

Phase _____

Maximum Fuse Size: _____ A

Minimum Wire Ampacity: _____ A

© May, 2003 Taylor
All rights reserved.
059060-M



*The word Taylor and the Crown design
are registered trademarks in the United States
of America and certain other countries.*

Taylor Company
750 N. Blackhawk Blvd.
Rockton, IL 61072

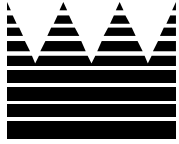

Table of Contents

Section 1	To the Installer	1
Section 2	To the Operator	4
Section 3	Safety	5
Section 4	Operator Parts Identification	7
	Model C707	7
	Model C707 Single Spout Door and Beater Assembly	8
	Brushes	9
Section 5	Important: To the Operator	10
	Symbol Definitions	11
	Power Switch	11
	Indicator Lights	11
	MIX REF Key	11
	STANDBY Key	11
	WASH Key	11
	AUTO Key	12
	Beater Motor Reset Button	12
	Adjustable Draw Handle	12
	Feed Tube Assembly	13
Section 6	Operating Procedures	14
	Assembly	14
	Sanitizing	18
	Priming	20
	Closing Procedure	20
	Draining Product From the Freezing Cylinder	21

Rinsing	21
Cleaning	21
Disassembly	22
Brush Cleaning	22
Section 7 Important: Operator Checklist	23
During Cleaning and Sanitizing	23
Troubleshooting Bacterial Count	23
Regular Maintenance Checks	23
Winter Storage	24
Section 8 Troubleshooting Guide	25
Section 9 Parts Replacement Schedule	27
Section 10 Parts List	28
Wiring Diagrams	35

Note: Continuing research results in steady improvements; therefore, information in this manual is subject to change without notice.

Note: Only instructions originating from the factory or its authorized translation representative(s) are considered to be the original set of instructions.

© May, 2003 Taylor (Original Publication)
(Updated September, 2011)
All rights reserved.
059060-M



*The word Taylor and the Crown design
are registered trademarks in the United States
of America and certain other countries.*

Taylor Company
750 N. Blackhawk Blvd.
Rockton, IL 61072

Section 1

To the Installer

The following are general installation instructions. For complete installation details, please see the checkout card.

Installer Safety



In all areas of the world, equipment should be installed in accordance with existing local codes. Please contact your local authorities if you have any questions.

Care should be taken to ensure that all basic safety practices are followed during the installation and servicing activities related to the installation and service of Taylor equipment.

- Only authorized Taylor service personnel should perform installation and repairs on the equipment.
- Authorized service personnel should consult OSHA Standard 29CFR1910.147 or the applicable code of the local area for the industry standards on lockout/tagout procedures before beginning any installation or repairs.
- Authorized service personnel must ensure that the proper PPE is available and worn when required during installation and service.
- Authorized service personnel must remove all metal jewelry, rings, and watches before working on electrical equipment.



The main power supply(s) to the freezer must be disconnected prior to performing any repairs. Failure to follow this instruction may result in personal injury or death from electrical shock or hazardous moving parts as well as poor performance or damage to the equipment.

Note: All repairs must be performed by an authorized Taylor Service Technician.



This unit has many sharp edges that can cause severe injuries.

Site Preparation

Review the area where the unit will be installed before uncrating the unit. Make sure all possible hazards to the user or equipment have been addressed.

Air Cooled Units

DO NOT obstruct air intake and discharge openings:

The Model C707 air cooled unit requires a minimum of 6" (152 mm) of clearance on both sides and 0" in the rear of the unit. This will allow for adequate air flow across the condenser(s). Failure to allow adequate clearance can reduce the refrigeration capacity of the freezer and possibly cause permanent damage to the compressor.

For Indoor Use Only: This unit is designed to operate indoors, under normal ambient temperatures of 70°-75°F (21°-24°C). The freezer has successfully performed in high ambient temperatures of 104° (40°C) at reduced capacities.



This unit must **NOT** be installed in an area where a water jet or hose can be used. **NEVER** use a water jet or hose to rinse or clean the unit. Failure to follow this instruction may result in electrocution.



This unit must be installed on a level surface to avoid the hazard of tipping. Extreme care should be taken in moving this equipment for any reason. Two or more persons are required to safely move this unit. Failure to comply may result in personal injury or equipment damage.

Uncrate the unit and inspect it for damage. Report any damage to your Taylor Distributor.

This piece of equipment is made in the USA and has USA sizes of hardware. All metric conversions are approximate and vary in size.

Water Connections (Water Cooled Units Only)

An adequate cold water supply must be provided with a hand shut-off valve. On the underside rear of the base pan, two 3/8" I.P.S. water connections for inlet and outlet have been provided for easy hook-up. 1/2" inside diameter water lines should be connected to the machine. (Flexible lines are recommended, if local codes permit.) Depending on local water conditions, it may be advisable to install a water strainer to prevent foreign substances from clogging the automatic water valve. There will be only one water "in" and one water "out" connection. **DO NOT** install a hand shut-off valve on the water "out" line! Water should always flow in this order: first, through the automatic water valve; second, through the condenser; and third, through the outlet fitting to an **open trap drain**.



A back flow prevention device is required on the incoming water connection side. Please refer to the applicable National, State, and local codes for determining the proper configuration.

Electrical Connections

In the United States, this equipment is intended to be installed in accordance with the National Electrical Code (NEC), ANSI/NFPA 70-1987. The purpose of the NEC code is the practical safeguarding of persons and property from hazards arising from the use of electricity. This code contains provisions considered necessary for safety. In all other areas of the world, equipment should be installed in accordance with the existing local codes. Please contact your local authorities.



FOLLOW YOUR LOCAL ELECTRICAL CODES!

Each unit requires one power supply for each data label on the unit. Check the data label(s) on the freezer for branch circuit overcurrent protection or fuse, circuit ampacity, and other electrical specifications. Refer to the wiring diagram provided inside of the electrical box for proper power connections.



CAUTION: THIS EQUIPMENT MUST BE PROPERLY GROUNDED! FAILURE TO DO SO CAN RESULT IN SEVERE PERSONAL INJURY FROM ELECTRICAL SHOCK!



DO NOT operate this freezer with larger fuses than specified on the unit data label. Failure to follow this instruction may result in electrocution or damage to the machine.



This unit is provided with an equipotential grounding lug that is to be properly attached to the rear of the frame by the authorized installer. The installation location is marked by the equipotential bonding symbol (5021 of IEC 60417-1) on both the removable panel and the equipments frame.



Stationary appliances which are not equipped with a power cord and a plug or another device to disconnect the appliance from the power source must have an all-pole disconnecting device with a contact gap of at least 3 mm installed in the external installation.



Appliances that are permanently connected to fixed wiring and for which leakage currents may exceed 10 mA, particularly when disconnected or not used for long periods, or during initial installation, shall have protective devices such as a GFI, to protect against the leakage of current, installed by the authorized personnel to the local codes.



Supply cords used with this unit shall be oil-resistant, sheathed flexible cable not lighter than ordinary polychloroprene or other equivalent synthetic elastomer-sheathed cord (Code designation 60245 IEC 57) installed with the proper cord anchorage to relieve conductors from strain, including twisting, at the terminals and protect the insulation of the conductors from abrasion.

Beater Rotation



Beater rotation must be clockwise as viewed looking into the freezing cylinder.

Note: The following procedures should be performed by a trained service technician.

To correct the rotation on a three-phase unit, interchange any two incoming power supply lines at freezer main terminal block only.

To correct rotation on a single-phase unit, change the leads inside the beater motor. (Follow the diagram printed on the motor.)

Electrical connections are made directly to the terminal block provided in the main control box.

Refrigerant



In consideration of our environment, Taylor proudly uses only earth friendly HFC refrigerants. The HFC refrigerant used in this unit is R404A. This refrigerant is generally considered non-toxic and non-flammable, with an Ozone Depleting Potential (ODP) of zero (0).

However, any gas under pressure is potentially hazardous and must be handled with caution.

NEVER fill any refrigerant cylinder completely with liquid. Filling the cylinder to approximately 80% will allow for normal expansion.



Refrigerant liquid sprayed onto the skin may cause serious damage to tissue. Keep eyes and skin protected. If refrigerant burns should occur, flush immediately with cold water. If burns are severe, apply ice packs and contact a physician immediately.

Taylor reminds technicians to be cautious of government laws regarding refrigerant recovery, recycling, and reclaiming systems. If you have any questions regarding these laws, please contact the factory Service Department.



WARNING: R404A refrigerant used in conjunction with polyolester oils is extremely moisture absorbent. When opening a refrigeration system, the maximum time the system is open must not exceed 15 minutes. Cap all open tubing to prevent humid air or water from being absorbed by the oil.

Section 2

To the Operator

The Model C707 has been carefully engineered and manufactured to give you dependable operation.

This unit, when properly operated and cared for, will produce a consistent quality product. Like all mechanical products, it will require cleaning and maintenance. A minimum amount of care and attention is necessary if the operating procedures outlined in this manual are followed closely.

This Operator's Manual should be read before operating or performing any maintenance on your equipment.

Your Taylor freezer will NOT eventually compensate for and correct any errors during the set-up or filling operations. Thus, the initial assembly and priming procedures are of extreme importance. It is strongly recommended that personnel responsible for the equipment's operation, both assembly and disassembly, go through these procedures together in order to be properly trained and to make sure that no confusion exists.

In the event you should require technical assistance, please contact your local authorized Taylor Distributor.

Note: Warranty is valid only if the parts are authorized Taylor parts, purchased from an authorized Taylor Distributor, and the required service work is provided by an authorized Taylor service technician. Taylor reserves the right to deny warranty claims on equipment or parts if non-approved parts or refrigerant were installed in the machine, system modifications were performed beyond factory recommendations, or it is determined that the failure was caused by neglect or abuse.



If the crossed out wheeled bin symbol is affixed to this product, it signifies that this product is compliant with the EU Directive as well as other similar legislation in effect after August 13, 2005. Therefore, it must be collected separately after its use is completed, and cannot be disposed as unsorted municipal waste.

The user is responsible for returning the product to the appropriate collection facility, as specified by your local code.

For additional information regarding applicable local laws, please contact the municipal facility and/or local distributor.

Compressor Warranty Disclaimer

The refrigeration compressors on this machine are warranted for the term indicated on the warranty card accompanying this machine. However, due to the Montreal Protocol and the U.S. Clean Air Act Amendments of 1990, many new refrigerants are being tested and developed, thus seeking their way into the service industry. Some of these new refrigerants are being advertised as drop-in replacements for numerous applications. It should be noted that, in the event of ordinary service to this machine's refrigeration system, **only the refrigerant specified on the affixed data label should be used.** The unauthorized use of alternate refrigerants will void your compressor warranty. It will be the owner's responsibility to make this fact known to any technician he employs.

It should also be noted that Taylor does not warrant the refrigerant used in its equipment. For example, if the refrigerant is lost during the course of ordinary service to this machine, Taylor has no obligation to either supply or provide its replacement either at billable or unbillable terms. Taylor does have the obligation to recommend a suitable replacement if the original refrigerant is banned, obsoleted, or no longer available during the five year warranty of the compressor.

Taylor will continue to monitor the industry and test new alternates as they are being developed. Should a new alternate prove, through our testing, that it would be accepted as a drop-in replacement, then the above disclaimer would become null and void. To find out the current status of an alternate refrigerant as it relates to your compressor warranty, call the local Taylor Distributor or the Taylor Factory. Be prepared to provide the Model/Serial Number of the unit in question.

We, at Taylor Company, are concerned about the safety of the operator when he or she comes in contact with the freezer and its parts. Taylor has gone to extreme efforts to design and manufacture built-in safety features to protect both you and the service technician. As an example, warning labels have been attached to the freezer to further point out safety precautions to the operator.



IMPORTANT - Failure to adhere to the following safety precautions may result in severe personal injury or death. Failure to comply with these warnings may damage the machine and its components. Component damage will result in part replacement expense and service repair expense.



DO NOT operate the freezer without reading this Operator Manual. Failure to follow this instruction may result in equipment damage, poor freezer performance, health hazards, or personal injury.

Per IEC 60335-1 and its part 2 standards, “This appliance is to be used only by trained personnel. It is not intended for use by children or people with reduced physical, sensory, or mental capabilities, or lack of experience and knowledge, unless given supervision or instruction concerning the use of the appliance by a person responsible for their safety.”



This unit is provided with an equipotential grounding lug that is to be properly attached to the rear of the frame by the authorized installer. The installation location is marked by the equipotential bonding symbol (5021 of IEC 60417-1) on both the removable panel and the equipments frame.



DO NOT use a water jet to clean or rinse the freezer. Failure to follow these instructions may result in serious electrical shock.



- **DO NOT** operate the freezer unless it is properly grounded.
- **DO NOT** operate the freezer with larger fuses than specified on the freezer data label.
- All repairs must be performed by an authorized Taylor service technician. The main power supplies to the machine must be disconnected prior to performing any repairs.
- Cord Connected Units: Only Taylor authorized service technicians may install a plug on this unit.
- Stationary appliances which are not equipped with a power cord and a plug or another device to disconnect the appliance from the power source must have an all-pole disconnecting device with a contact gap of at least 3 mm installed in the external installation.
- Appliances that are permanently connected to fixed wiring and for which leakage currents may exceed 10 mA, particularly when disconnected or not used for long periods, or during initial installation, shall have protective devices such as a GFI, to protect against the leakage of current, installed by the authorized personnel to the local codes.
- Supply cords used with this unit shall be oil-resistant, sheathed flexible cable not lighter than ordinary polychloroprene or other equivalent synthetic elastomer-sheathed cord (Code designation 60245 IEC 57) installed with the proper cord anchorage to relieve conductors from strain, including twisting, at the terminals and protect the insulation of the conductors from abrasion.

Failure to follow these instructions may result in electrocution. Contact your local authorized Taylor Distributor for service.



- **DO NOT** allow untrained personnel to operate this machine.
- **DO NOT** operate the freezer unless all service panels and access doors are restrained with screws.
- **DO NOT** remove any internal operating parts (examples: freezer door, beater, scraper blades, etc.) unless all control switches are in the OFF position.

Failure to follow these instructions may result in severe personal injury to fingers or hands from hazardous moving parts.



This unit has many sharp edges that can cause severe injuries.

- **DO NOT** put objects or fingers in the door spout. This may contaminate the product and cause severe personal injury from blade contact.
- **USE EXTREME CAUTION** when removing the beater assembly. The scraper blades are very sharp.
- **CAUTION-SHARP EDGES:** Two people are required to handle the cup/cone dispenser. Protective gloves must be worn and the mounting holes must NOT be used to lift or hold the dispenser. Failure to follow this instruction can result in personal injury to fingers or equipment damage.



Cleaning and sanitizing schedules are governed by your state or local regulatory agencies and must be followed accordingly. Please refer to the cleaning section of this manual for the proper procedure to clean this unit.

DO NOT obstruct air intake and discharge openings:

The Model C707 air cooled unit requires a minimum of 6" (152 mm) of clearance on both sides and 0" in the rear of the unit. This will allow for adequate air flow across the condenser(s). Failure to allow adequate clearance can reduce the refrigeration capacity of the freezer and possibly cause permanent damage to the compressor.

For Indoor Use Only: This unit is designed to operate indoors, under normal ambient temperatures of 70° - 75°F (21° - 24°C). The freezer has successfully performed in high ambient temperatures of 104° (40°C) at reduced capacities.

NOISE LEVEL: Airborne noise emission does not exceed 78 dB(A) when measured at a distance of 1.0 meter from the surface of the machine and at a height of 1.6 meters from the floor.

Section 4

Operator Parts Identification

Model C707

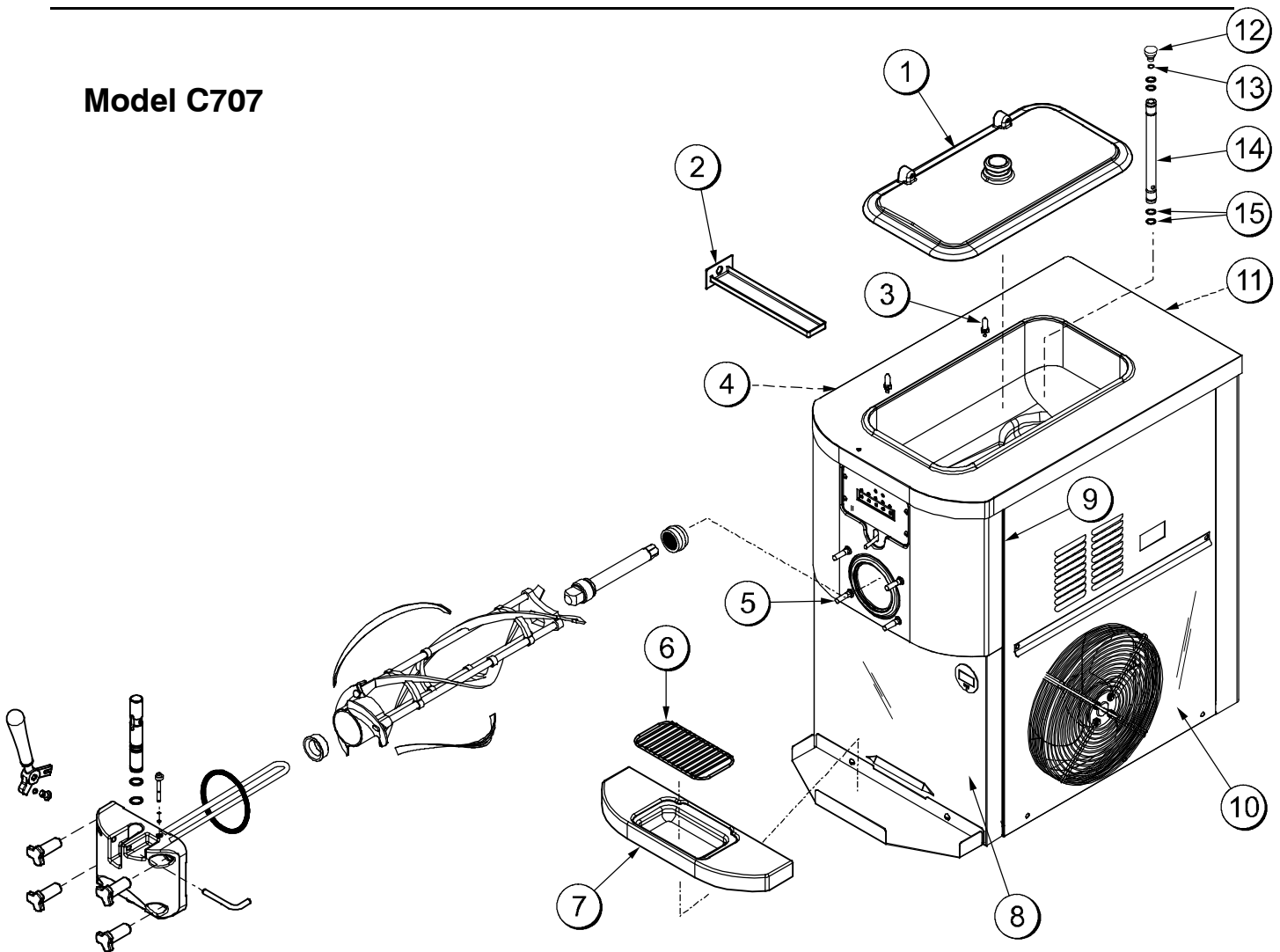

ITEM	DESCRIPTION	PART NO.
1	COVER-HOPPER COMPLETE	053809-1
2	PAN-DRIP 11-5/8 LONG	027503
3	PIN-RETAINING-HOPPER CVR	043934
4	PANEL-SIDE-LEFT	056082-SP3
5	STUD-NOSE CONE	055987
6	SHIELD-SPLASH	049203
7	TRAY-DRIP	056858
8	PANEL-FRONT-LOWER	058942

ITEM	DESCRIPTION	PART NO.
9	PANEL A.-FRONT UPPER	X58950
10	PANEL A.-RIGHT	X64151
11	PANEL-REAR	056077-SP1
12	ORIFICE	022465-100
13	O-RING-3/8 OD X .070 W	016137
14	TUBE A.-FEED	X29429-2
15	O-RING-.643 OD X .077 W	018572

080715

Model C707 Single Spout Door and Beater Assembly

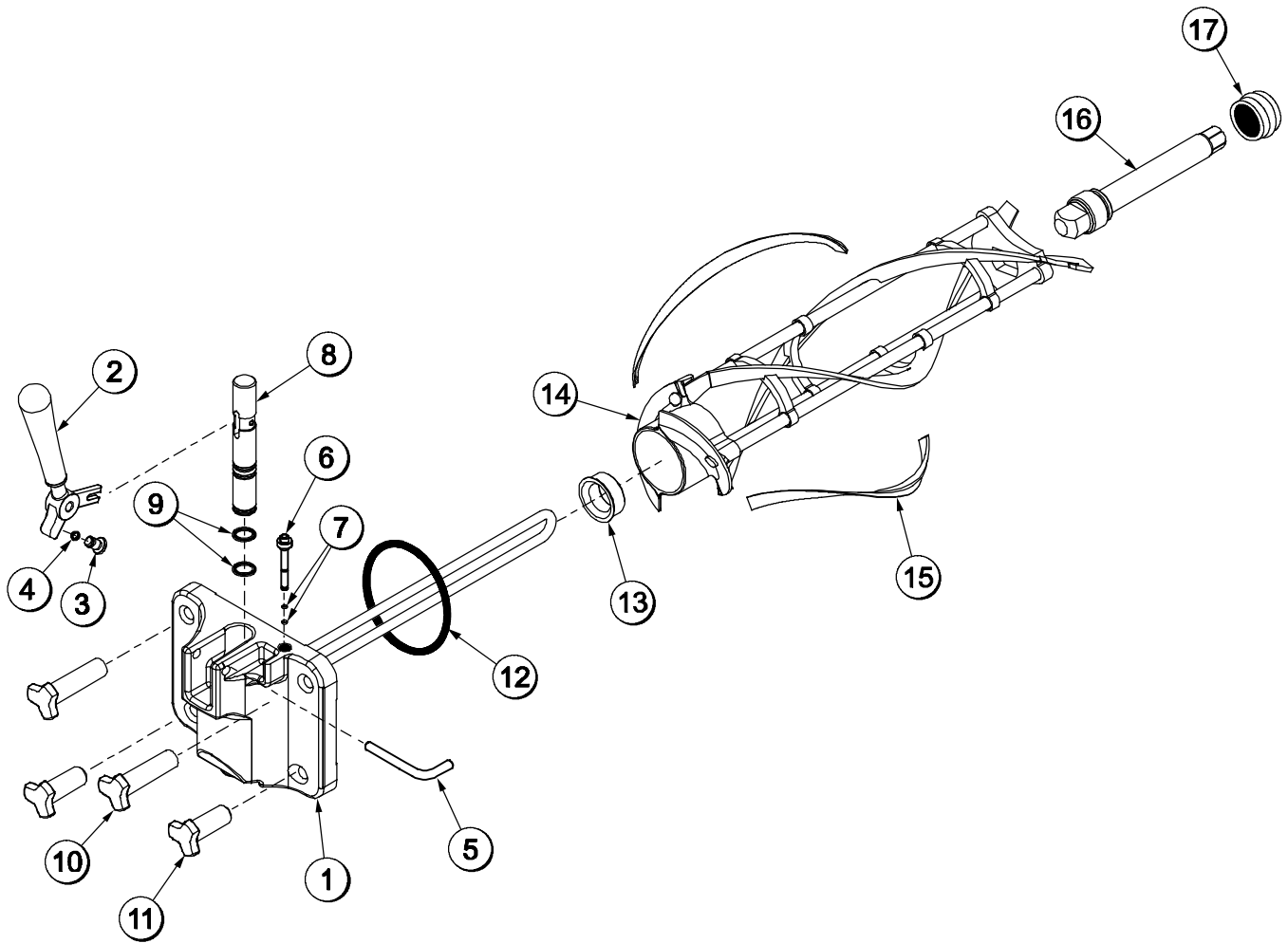

ITEM	DESCRIPTION	PART NO.
1	DOOR A.-W/BAFFLE	X56071-SER
2	HANDLE A.-DRAW-WELDED	X56246
3	SCREW-ADJUSTMENT-5/16-24	056332
4	O-RING-1/4 OD X .070W 50	015872
5	PIN-HANDLE-SS	055819
6	PLUG-PRIME	028805
7	O-RING-3/8 OD X .070W	016137
8	VALVE A.-DRAW	X56072
9	O-RING-7/8 OD X .103W	014402

ITEM	DESCRIPTION	PART NO.
10	NUT-STUD-LONG	058765
11	NUT-STUD	058764
12	GASKET-DOOR HT 4"-DBL	048926
13	BEARING-FRONT	050216
14	BEATER A.-3.4QT	X31761
15	BLADE-SCRAPER-PLASTIC	035174
16	SHAFT-BEATER	056078
17	SEAL-DRIVE SHAFT	032560

Brushes

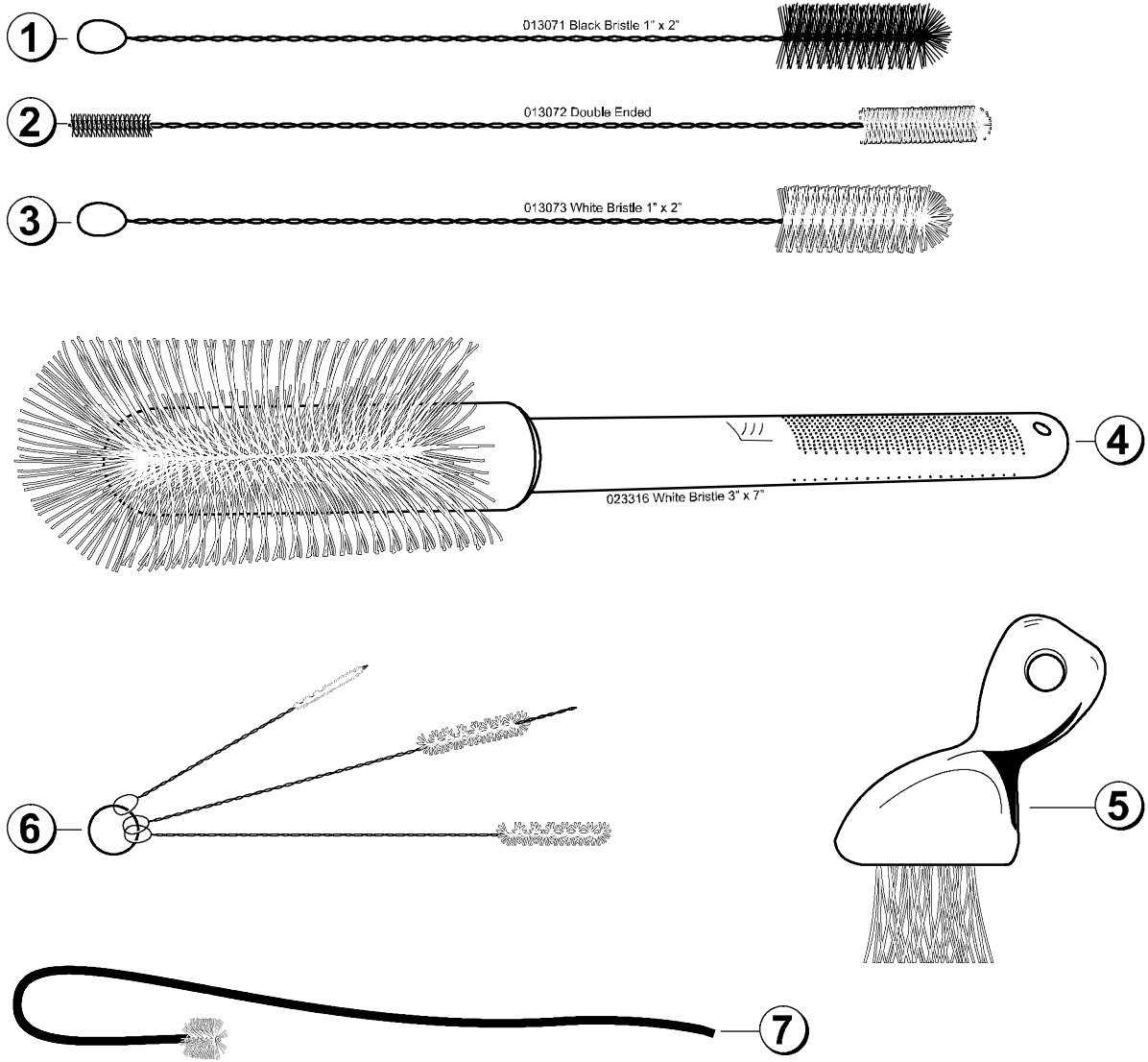

ITEM	DESCRIPTION	PART NO.
1	BLACK BRISTLE BRUSH	013071
2	DOUBLE END BRUSH	013072
3	WHITE BRISTLE BRUSH (1" x 2")	013073
4	WHITE BRISTLE BRUSH (3" x 7")	023316

ITEM	DESCRIPTION	PART NO.
5	BRUSH-END-DOOR SPOUT SS	039719
6	BRUSH-SET LVB	050103
7	BRUSH-PUMP SPOUT	054068

Section 5

Important: To the Operator

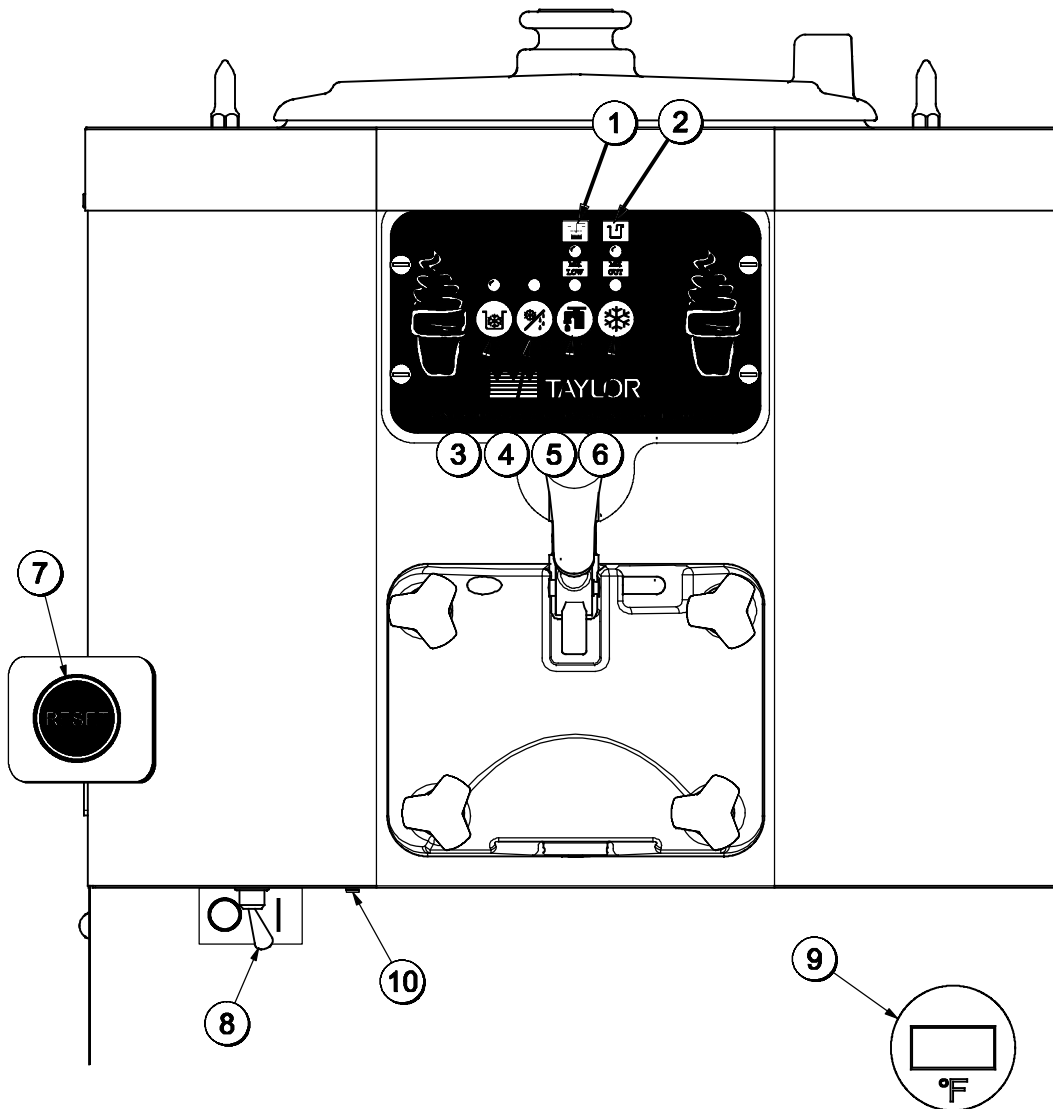









ITEM	DESCRIPTION
1	MIX LOW INDICATOR LIGHT
2	MIX OUT INDICATOR LIGHT
3	MIX REFRIGERATION KEY
4	STANDBY KEY
5	WASH KEY

ITEM	DESCRIPTION
6	AUTO KEY
7	RESET BUTTON - BEATER MOTOR
8	POWER SWITCH (TOGGLE)
9	HOPPER TEMP. INDICATOR
10	FLAVOR BURST JACK

Symbol Definitions

To better communicate in the International arena, symbols have replaced words on many of our operator switches, function, and fault indicators. Your Taylor equipment is designed with these International symbols.

The following chart identifies the symbol definitions.

	= OFF
	= ON
	= MIX LOW
	= MIX OUT
	= MIX REF
	= STANDBY
	= WASH
	= AUTO

Power Switch

When placed in the ON position, the power switch allows SOFTECH control panel operation.

Indicator Lights

When the MIX LOW light begins to flash, it indicates that the mix tank has a low supply of mix and should be refilled as soon as possible. When the MIX OUT light begins to flash, it indicates that the mix tank has been almost completely exhausted and has an insufficient supply of mix to operate the freezer. At this time, the STANDBY and AUTO modes are locked out and the freezer shuts down. To initiate the refrigeration system, add mix to the tank and press the AUTO key. The freezer will automatically begin operation.

MIX REF Key

When the MIX REF key is pressed, the light comes on indicating the mix hopper refrigeration system is operating. The MIX REF function cannot be cancelled unless the AUTO or STANDBY modes are cancelled first.

STANDBY Key

The Separate Hopper Refrigeration System (SHR) and the Cylinder Temperature Retention System (CTR) are standard features. The SHR incorporates the use of a separate small refrigeration system to maintain the mix in the hopper below 40° (4.4°C) to assure bacteria control. The CTR works with the SHR to maintain a good quality product. During long “No Sale” periods, it is necessary to warm the product in the freezing cylinder to approximately 35°F to 40°F (1.7°C to 4.4°C) to prevent overbeating and product breakdown.

To activate the SHR and CTR, press the STANDBY key. Remove the air orifice and place the feed tube (**end without the hole**) into the mix inlet hole.

When the STANDBY key is pressed, the light comes on, indicating the CTR (Cylinder Temperature Retention System) has been activated. In the STANDBY mode, the WASH and AUTO functions are automatically cancelled. The MIX REF function is automatically locked in to maintain the mix in the hopper.

To resume normal operation, press the AUTO key. When the unit cycles off, the product in the freezing cylinder will be at serving viscosity. At this time, place the feed tube (**end with the hole**) into the mix inlet hole and install the air orifice.

WASH Key

When the WASH key is pressed, the light comes on. This indicates beater motor operation. The STANDBY or AUTO modes must be cancelled first to activate the WASH mode.

AUTO Key

When the AUTO key is pressed, the light comes on. This indicates that the main refrigeration system has been activated. In the AUTO mode, the WASH or STANDBY functions are automatically cancelled. The MIX REF function is automatically locked in to maintain the mix in the mix hopper.

Note: An indicating light and an audible tone will sound whenever a mode of operation has been pressed. To cancel any function, press the key again. The light and mode of operation will shut off.

Beater Motor Reset Button

The reset button is located on the left side of the unit. The reset protects the beater motor from an overload condition. If an overload occurs, the reset mechanism will trip. To properly reset the freezer, press the AUTO key to cancel the cycle. Turn the power switch to the OFF position. Press the reset button firmly.



Do not use metal objects to press the reset button. Failure to follow this instruction may result in electrocution.

Turn the power switch to the ON position. Press the WASH key and observe the freezer's performance. Open the side access panel. Make sure the beater motor is turning the drive shaft in a clockwise direction (from the operator end) without binding.

If the beater motor is turning properly, press the WASH key to cancel the cycle. Press the AUTO key to resume normal operation. If the freezer shuts down again, contact a service technician.

Adjustable Draw Handle

The Model C707 features an adjustable draw handle to provide the best portion control. The draw handle should be adjusted to provide a flow rate of 5 to 7-1/2 oz. of product per 10 seconds. To INCREASE the flow rate, turn the screw CLOCKWISE. Turn the screw COUNTER-CLOCKWISE to DECREASE the flow rate.

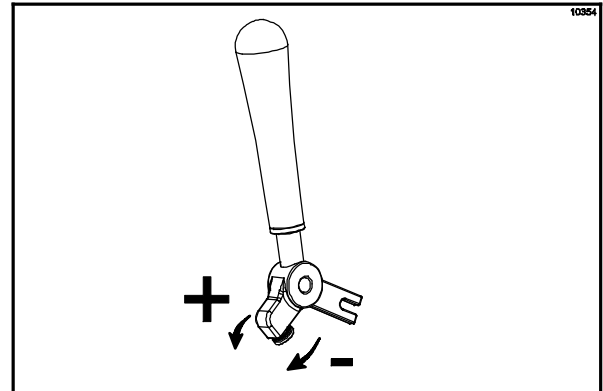

Figure 1

Feed Tube Assembly

The feed tube assembly serves two purposes. One end of the tube has a hole and the other end does not.

1. Normal Operation

During normal operation, the end of the feed tube with the hole is placed into the mix inlet hole. Every time the draw handle is raised, new mix and air from the hopper flow into the freezing cylinder. This keeps the freezing cylinder properly loaded and maintains overrun.

2. Long “No Sale” Periods

During long “No Sale” periods, the unit can be placed into the Standby mode. This maintains product temperatures below 40°F (4.4°C) in both the hopper and the freezing cylinder, and helps prevent overbeating and product breakdown.

To place the unit into the Standby mode, press the STANDBY key. Remove the air orifice. Lubricate the o-rings located on the end of the feed tube without the hole. Place that end of the tube into the mix inlet hole. This will prevent any mix from entering the freezing cylinder.

Note: The air orifice is used to meter a certain amount of air into the freezing cylinder. The air orifice maintains overrun and allows enough mix to enter the freezing cylinder after a draw.

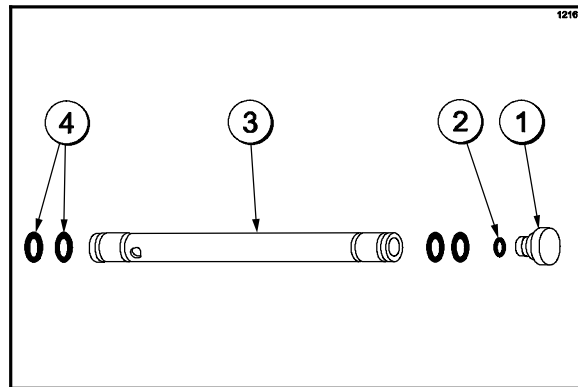

Figure 2

ITEM	DESCRIPTION	PART NO.
1	ORIFICE	022465-100
2	O-RING-3/8 OD X .070 W	016137
3	TUBE A.-FEED-SS 5/32 HOLE	X29429-2
4	O-RING-.643 OD X .077 W	018572

Section 6

Operating Procedures

The C707 unit stores mix in a hopper. It has a 3.4 quart (3.2 liter) capacity freezing cylinder and a 20 quart (18.9 liter) mix hopper. This unit uses a feed tube to allow mix to flow into the freezing cylinder.

We begin our instructions at the point where we enter the store in the morning and find the parts disassembled and laid out to air dry from the previous night's cleaning.

These opening procedures will show you how to assemble these parts into the freezer, sanitize them, and prime the freezer with fresh mix in preparation to serve your first portion.

If you are disassembling the machine for the first time or need information to get to this starting point in our instructions, turn to page 22, "Disassembly", and start there.

Assembly

Note: When lubricating parts, use an approved food grade lubricant (example: Taylor Lube).



MAKE SURE POWER SWITCH IS IN THE "OFF" POSITION! Failure to follow this instruction may result in severe personal injury from hazardous moving parts.

Step 1

Install the drive shaft. Lubricate the groove and shaft portion that comes in contact with the bearing on the beater drive shaft. Slide the seal over the shaft and groove until it snaps into place. **DO NOT** lubricate the hex end of the drive shaft.

Fill the inside portion of the seal with 1/4" more lubricant and lubricate the flat side of the seal that fits onto the rear shell bearing.

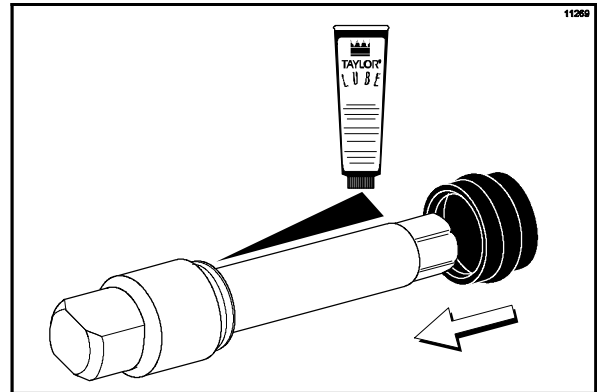

Figure 3

Insert the drive shaft into the freezing cylinder, hex end first, and into the rear shell bearing until the seal fits securely over the rear shell bearing. Engage the hex end firmly into the drive coupling. Be sure the drive shaft fits into the drive coupling without binding.

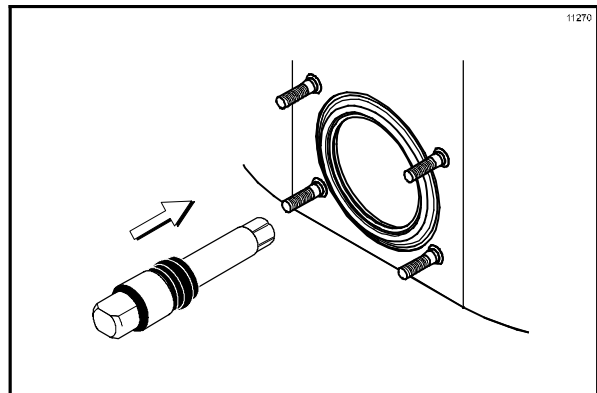

Figure 4



USE EXTREME CAUTION when handling the beater assembly. The scraper blades are very sharp and may cause injury.

Step 2

Install the beater assembly.

If the blades are in good condition, take one of the scraper blades and slip it under the hook at the front of the beater. Wrap the blade around the beater, following the helix and pushing the blade down onto the helix as you wrap. At the back end of the beater, slip the blade under the hook.

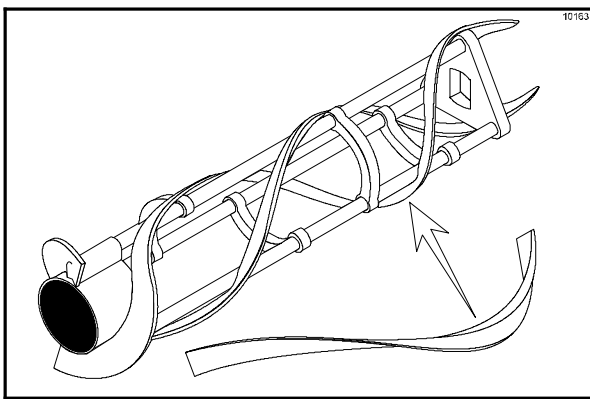

Figure 5

Repeat this step for the second scraper blade.

Holding the beater securely, slide the beater into the freezing cylinder about one-third of the way in. Looking into the freezing cylinder, align the hole at the rear of the beater with the flats on the end of the drive shaft.

Slide the beater the remainder of the way into the freezing cylinder and over the end of the drive shaft. The beater should fit snugly but not so tightly that the beater cannot be turned slightly to engage the drive shaft.

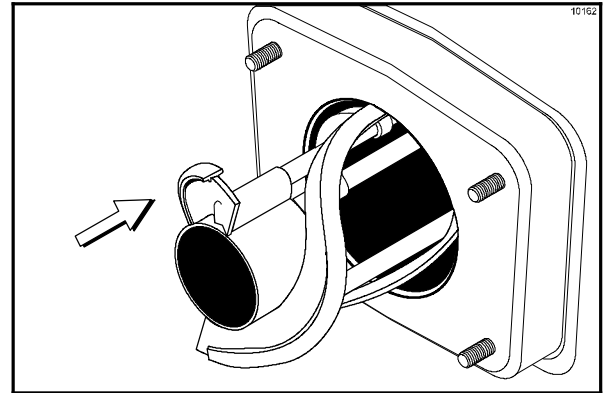

Figure 6

Make sure the beater assembly is in position over the drive shaft. Turn the beater slightly to be certain that the beater is properly seated. When in position, the beater will not protrude beyond the front of the freezing cylinder.

Step 3

Assemble the freezer door. Place the large rubber gasket into the groove on the back side of the freezer door.

Slide the white plastic front bearing over the baffle rod onto the bearing hub making certain that the flanged end of the bearing is resting against the freezer door.

Do not lubricate the gasket or the front bearing.

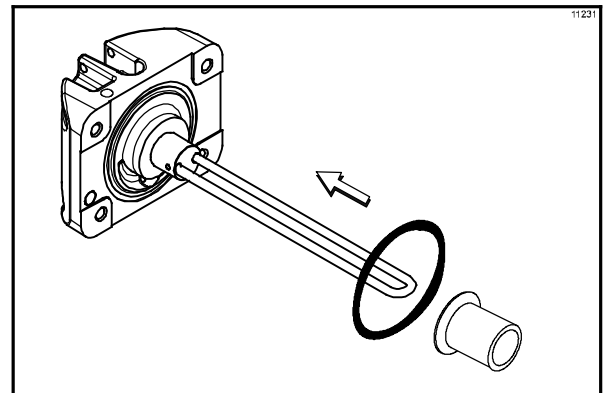

Figure 7

Step 4

Install the draw valve. Slide the two o-rings into the grooves on the draw valve, and lubricate.

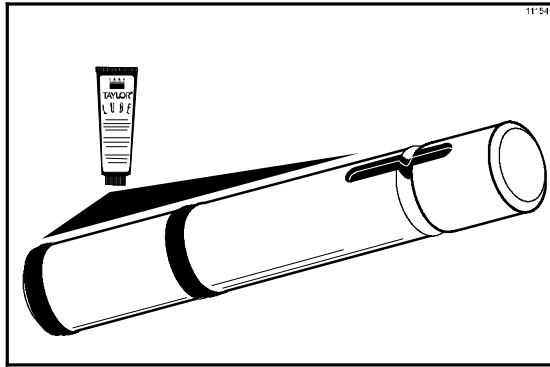

Figure 8

Lubricate the inside of the freezer door spout, top and bottom, and insert the draw valve from the **top** until the draw valve is at the bottom.

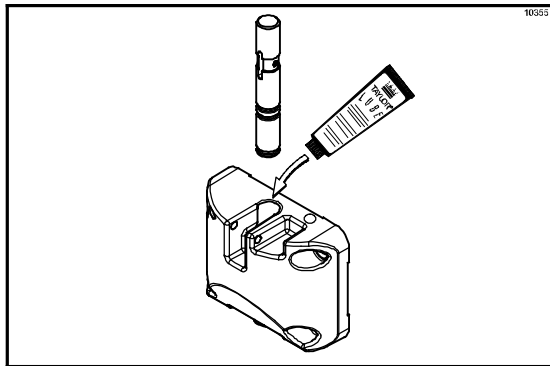

Figure 9

Slide the two o-rings into the grooves on the prime plug. Apply an even coat of Taylor Lube to the o-rings and shaft.

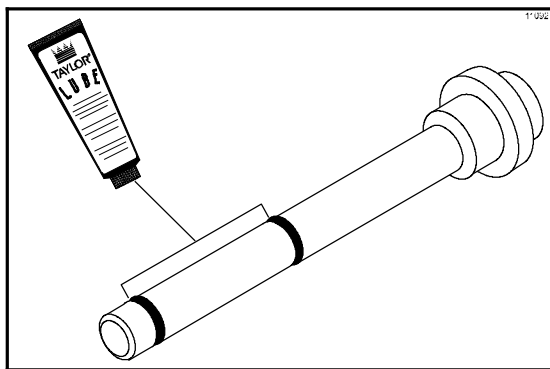

Figure 10

Insert the prime plug into the hole in the top of the freezer door, and push down.

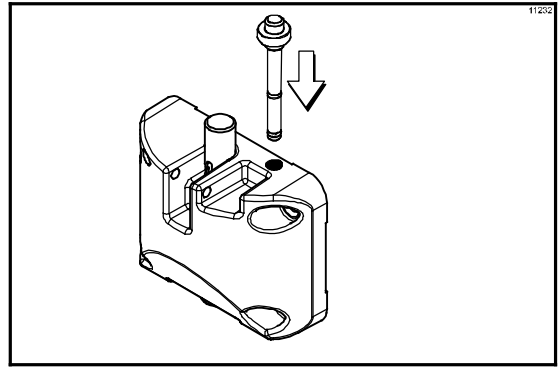

Figure 11

Step 5

Install the adjustable draw handle. Slide the fork over the bar in the slot of the draw valve. Secure with pivot pin.

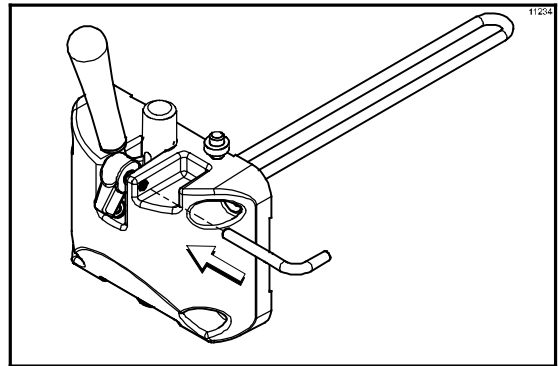

Figure 12

Note: This unit features an adjustable draw handle to provide the best portion control. The draw handle can be adjusted for different flow rates. See page 12 for more information on adjusting this handle.

Step 6

Install the freezer door. Insert the baffle rod through the opening in the beater and seat the door flush with the freezing cylinder. With the door seated on the freezer studs, install the handscrews. Tighten equally in a crisscross pattern to insure the door is snug.

Step 7

Install the front drip tray and the splash shield under the door spout.

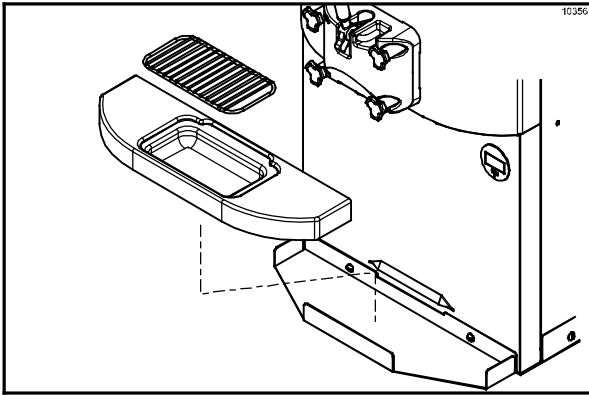

Figure 13

Step 8

Slide two o-rings on one end of the feed tube. Slide two o-rings on the other end of the feed tube.

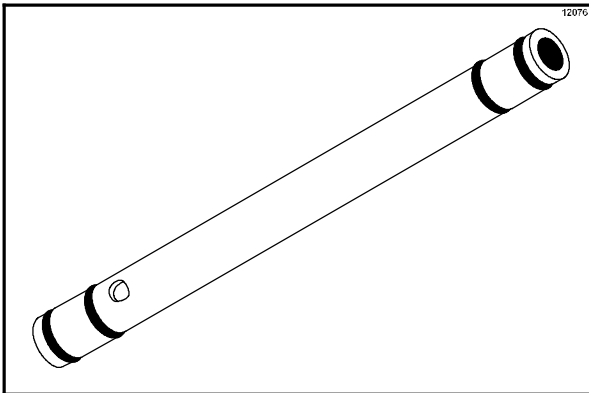

Figure 14

Slide the small o-ring into the groove of the air orifice. Do not lubricate the o-ring.

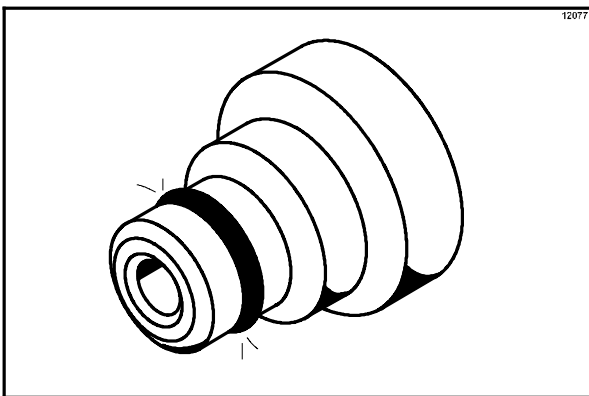

Figure 15

Note: Make sure the hole in the air orifice is clean and is not clogged. If the hole in the air orifice should become clogged, use soap and hot water to clear the hole. **Do not enlarge the hole in the air orifice.**

Install the air orifice into the hole in the top of the feed tube (in the end without the small hole on the side).

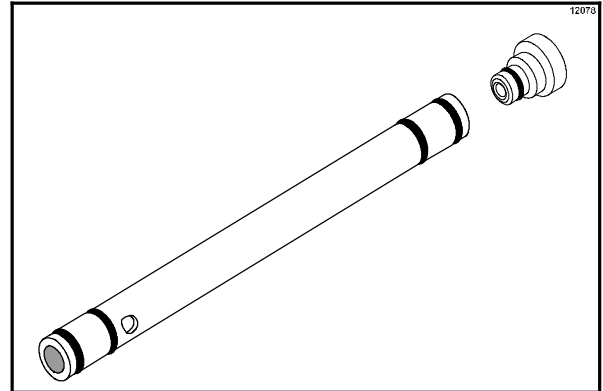

Figure 16

Step 9

Lay the feed tube (with the air orifice installed) and the hopper gasket in the bottom of the mix hopper for sanitizing.

Step 10

Slide the rear drip pan into the hole in the side panel.

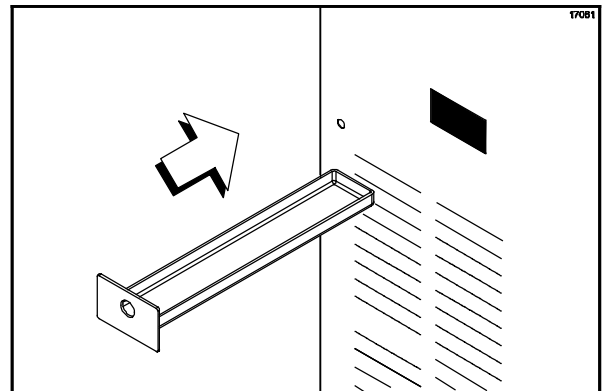

Figure 17

Sanitizing

Step 1

Prepare an approved 100 PPM sanitizing solution (examples: 2-1/2 gal. [9.5 liters] of Kay-5® or 2 gal. [7.6 liters] of Stera-Sheen®). USE WARM WATER AND FOLLOW THE MANUFACTURER'S SPECIFICATIONS.

Step 2

Pour the sanitizing solution over all the parts in the bottom of the mix hopper and allow it to flow into the freezing cylinder.

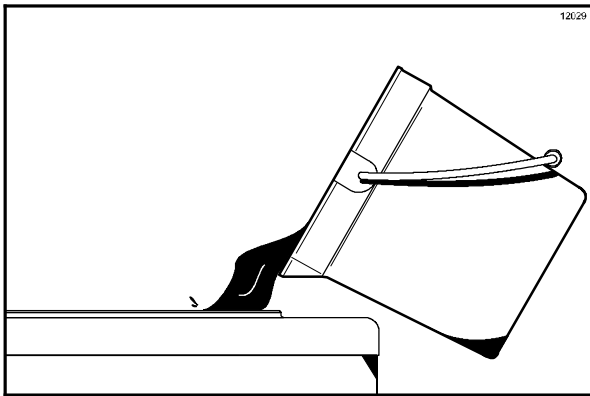

Figure 18

Note: You have just sanitized the mix hopper and parts; therefore, be sure your hands are clean and sanitized before going on in these instructions.

Step 3

While the solution is flowing into the freezing cylinder, take particular care to brush-clean the mix level sensing probe on the front wall and the bottom of the hopper, the mix hopper, and the feed tube.

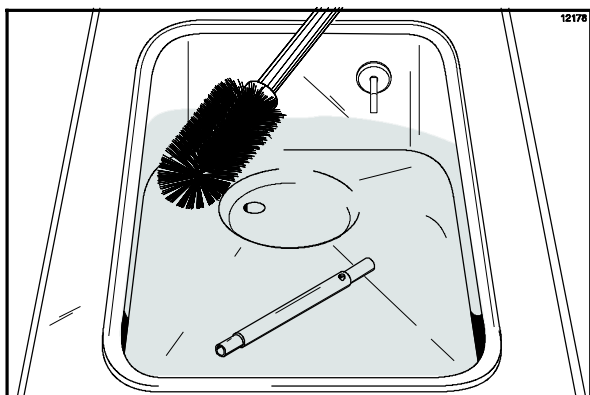

Figure 19

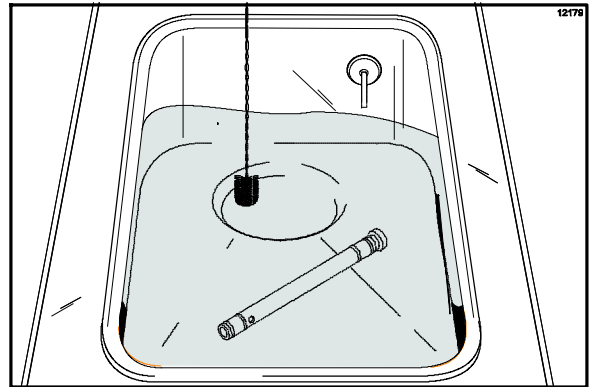

Figure 20

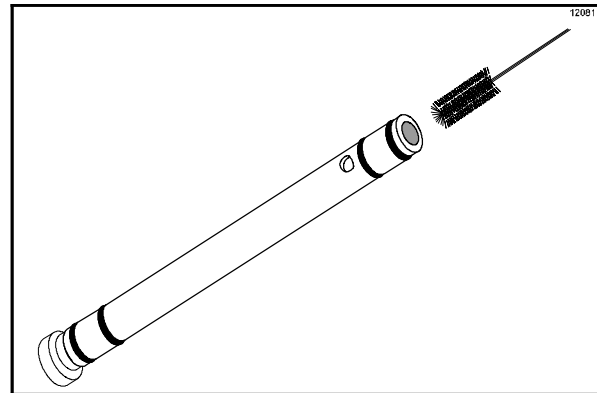

Figure 21

Step 4

Place the power switch in the ON position.

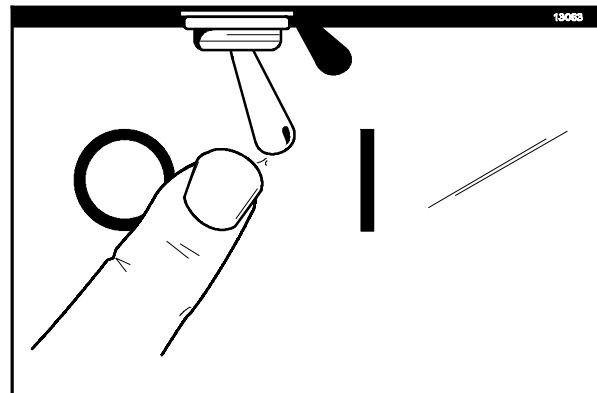

Figure 22

Step 5

Press the WASH key. This will cause the sanitizing solution in the freezing cylinder to agitate. Allow it to agitate for five minutes.

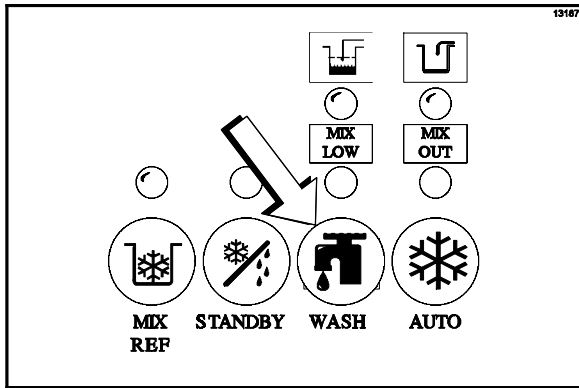

Figure 23

Step 6

With an empty pail beneath the door spout, raise the prime plug.

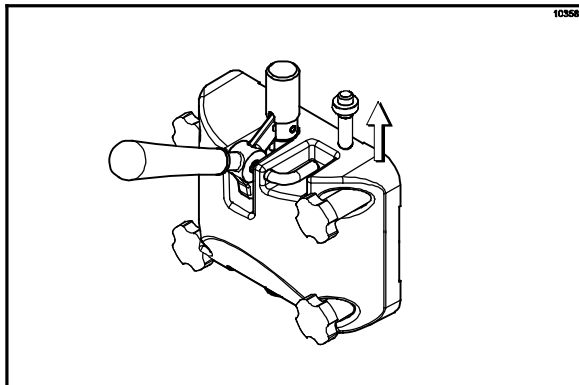

Figure 24

Step 7

When a steady stream of sanitizing solution is flowing from the prime plug opening in the bottom of the freezer door, pull the draw handle down. Draw off all of the sanitizing solution.

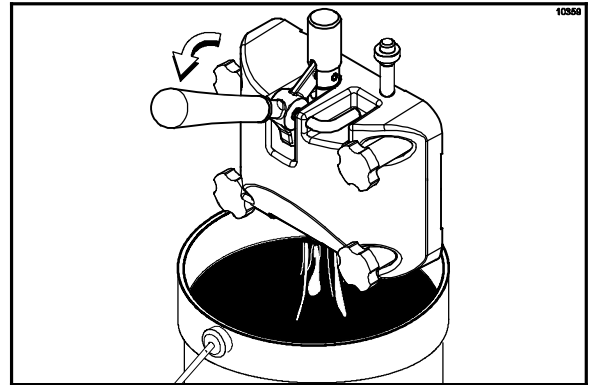

Figure 25

Step 8

Once the sanitizer stops flowing from the door spout, raise the draw handle. Press the WASH key, cancelling the beater motor operation.

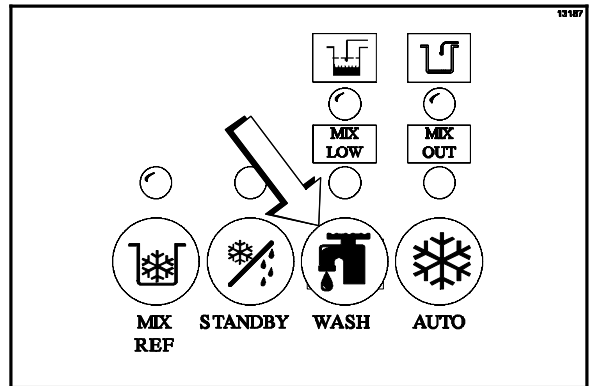

Figure 26

Note: Be sure your hands are clean and sanitized before continuing these instructions.

Step 9

Lubricate the mix feed tube o-rings located on the end of the tube with the small hole on the side. Stand the mix feed tube in the corner of the mix hopper.

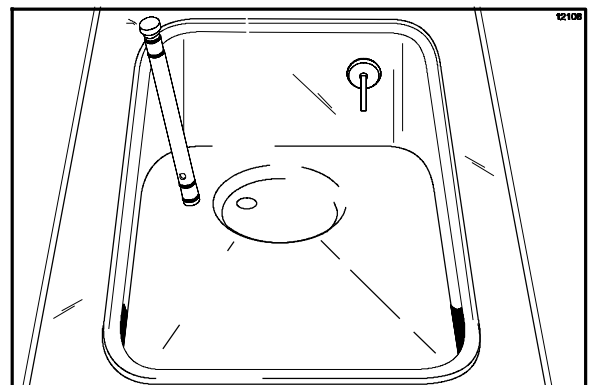

Figure 27

Priming

Step 1

Place an empty pail beneath the door spout and lower the draw handle. Be sure the prime plug is still in the UP position. Pour two gallons (7.6 liters) of **fresh** mix into the hopper and allow it to flow into the freezing cylinder. This will force out any remaining sanitizing solution. When full strength mix is flowing from the door spout, raise the draw handle.

Note: Use only fresh mix when priming the freezer.

Step 2

Once a **steady** stream of mix starts to flow from the prime plug opening in the bottom of the freezer door, push down the prime plug.

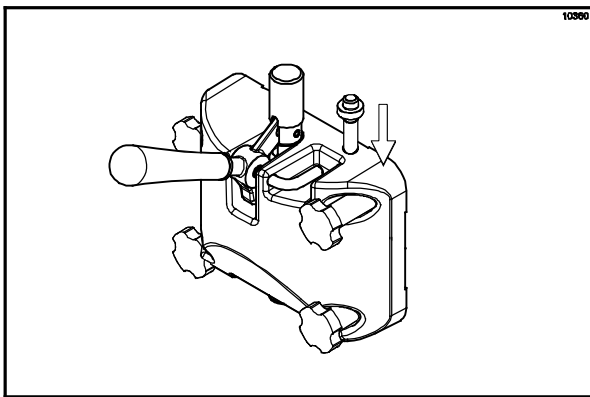

Figure 28

Step 3

When the mix stops bubbling down into the freezing cylinder, insert the mix feed tube.

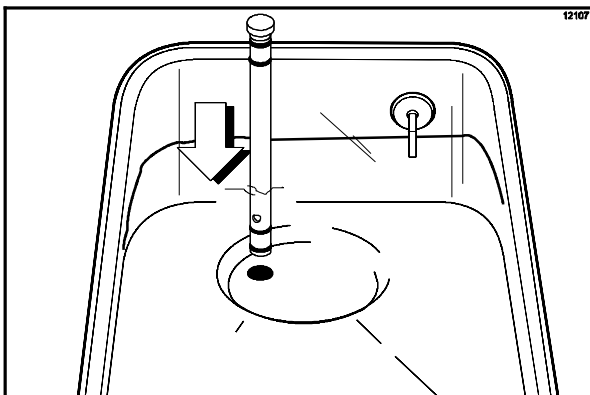

Figure 29

Step 4

Install the mix feed tube (the end with the hole) with the air orifice installed into the mix inlet hole in the mix hopper.

Step 5

Press the AUTO key. When the unit cycles off, the product will be at serving viscosity.

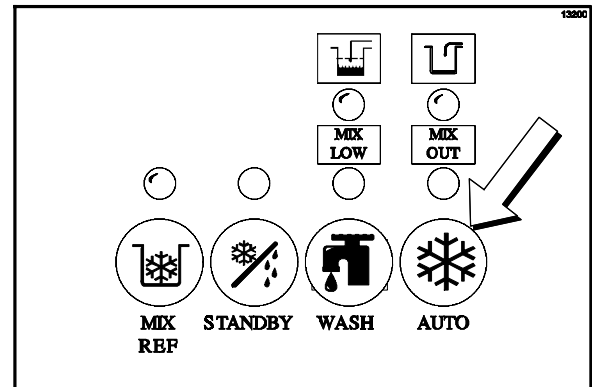

Figure 30

Step 6

Fill the hopper with **fresh** mix. As the mix level comes in contact with the mix level sensing probe on the front wall of the hopper, the MIX LOW light will shut off.

Note: The MIX REF light will come on, indicating the mix refrigeration system is maintaining mix in the mix hopper.

Step 7

Place the mix hopper cover in position.

Closing Procedure

To disassemble your unit, the following items will be needed:

- Two cleaning pails
- Sanitized stainless steel rerun can with lid
- Necessary brushes (provided with freezer)
- Cleaner
- Single service towels

Draining Product From the Freezing Cylinder

Step 1

Press the AUTO key, cancelling compressor and beater motor operation.

Press the MIX REF key, cancelling the mix hopper refrigeration system.

Step 2

Remove the hopper cover and take it to the sink for cleaning.

Step 3

If local health codes permit the use of rerun, place a sanitized, NSF approved stainless steel rerun container beneath the door spout. Press the WASH key and lower the draw handle. Drain the remaining product from the freezing cylinder and mix hopper. When the flow of product stops, press the WASH key and raise the draw handle. Place the sanitized lid on the rerun container and place it in the walk-in cooler.

Note: If local health codes DO NOT permit the use of rerun, the product must be discarded. Drain the product into a mix pail and properly discard it.

Step 4

Remove the assembled mix feed tube and take it to the sink for further disassembly and cleaning.



Rinsing

Step 1

Pour two gallons (7.6 liters) of **cool** clean water into the mix hopper. With the brushes provided, scrub the mix hopper, the mix inlet hole and the mix level sensing probe.

Step 2

With a pail beneath the door spout, raise the prime plug and press the WASH key.

Step 3

When a steady stream of rinse water is flowing from the prime plug opening in the bottom of the freezer door, lower the draw handle. Drain all the rinse water from the freezing cylinder. When the water stops flowing from the door spout, raise the draw handle and press the WASH key cancelling the WASH mode.

Repeat this procedure until the rinse water being drawn from the freezing cylinder is **clear**.

Cleaning

Step 1

Prepare an approved 100 PPM cleaning solution (examples: 2-1/2 gal. [9.5 liters] of Kay-5® or 2 gal. [7.6 liters] of Stera-Sheen®). **USE WARM WATER AND FOLLOW THE MANUFACTURER'S SPECIFICATIONS.**

Step 2

Push down the prime plug. Pour the cleaning solution into the mix hopper.

Step 3

While the solution is flowing into the freezing cylinder, brush clean the mix hopper, mix level sensing probes and the mix inlet hole.

Step 4

Press the WASH key. This will cause the cleaning solution in the freezing cylinder to be agitated.

Step 5

Place an empty pail beneath the door spout and raise the prime plug.

Step 6

When a steady stream of cleaning solution is flowing from the prime plug opening in the bottom of the freezer door, lower the draw handle. Draw off all of the solution.

Step 7

Once the cleaning solution stops flowing from the door spout, raise the draw handle and press the WASH key, cancelling the WASH mode.

Disassembly

Step 1

Be sure the power switch is in the OFF position.

Make sure no lights are lit on the control panel.

Step 2

Remove the handscrews, freezer door, beater, beater, scraper blades, and drive shaft from the freezing cylinder. Take these parts to the sink for cleaning.

Step 3

Remove the feed tube, the front drip tray and the splash shield.

Brush Cleaning

Make sure all brushes provided with the freezer are available for brush cleaning.

Step 1

Prepare a sink with an approved cleaning solution (examples: Kay-5® or Stera-Sheen®). **USE WARM WATER AND FOLLOW THE MANUFACTURER'S SPECIFICATIONS.** If another approved cleaner is used, dilute according to label instructions.

IMPORTANT: Follow label directions, as too **STRONG** of a solution can cause parts damage, while too **MILD** of a solution will not provide adequate cleaning. Make sure all brushes provided with the freezer are available for brush cleaning.

Step 2

Remove the seal from the drive shaft.

Step 3

From the freezer door remove the gasket, front bearing, pivot pin, adjustable draw handle, draw valve, and prime plug. Remove all o-rings.

Note: To remove the o-rings, use a single service towel to grasp the o-ring. Apply pressure in an upward direction until the o-ring pops out of its groove. With the other hand, push the top of the o-ring forward and it will roll out of the groove and can be easily removed. If there is more than one o-ring to be removed, always remove the rear o-ring first. This will allow the o-ring to slide over the forward rings without falling into the open grooves.

Step 4

Return to the freezer with a small amount of cleaning solution. With the black bristle brush, brush clean the rear shell bearing at the back of the freezing cylinder. Brush clean the drive hub opening in the rear wall of the mix hopper.

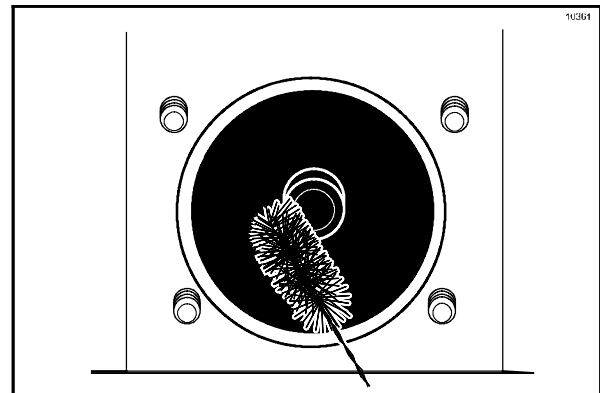

Figure 31

Step 5

Remove the rear drip pan from the side panel and take it to the sink for cleaning.

Note: If the drip pan is filled with an excessive amount of mix, refer to the Troubleshooting Guide.

Step 6

Thoroughly brush clean all disassembled parts in the cleaning solution, making sure all lubricant and mix film is removed. Take particular care to brush clean the hole for the draw valve in the freezer door. Place all cleaned parts on a clean, dry surface to air dry overnight.

Step 7

Wipe clean all exterior surfaces of the freezer.

Section 7 Important: Operator Checklist

During Cleaning and Sanitizing



Cleaning and sanitizing schedules are governed by federal, state, or local regulatory agencies, and must be followed accordingly. If the unit has a “Standby mode”, it must not be used in lieu of proper cleaning and sanitizing procedures and frequencies set forth by the ruling health authority. The following check points should be stressed during the cleaning and sanitizing operations.

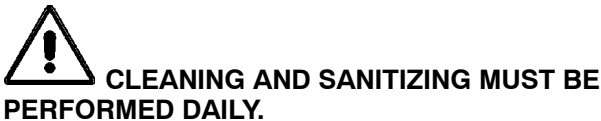

Troubleshooting Bacterial Count

- 1. Thoroughly clean and sanitize machine regularly, including complete disassembly and brush cleaning.
- 2. Use all brushes supplied for thorough cleaning. The brushes are specially designed to reach all mix passageways.
- 3. Use the white bristle brush to clean the mix inlet hole which extends from the mix hopper down to the rear of the freezing cylinder.
- 4. Use the black bristle brush to thoroughly clean the rear shell bearing located at the rear of the freezing cylinder. Be sure to have a generous amount of cleaning solution on the brush.
- 5. IF LOCAL HEALTH CODES PERMIT THE USE OF RERUN, make sure the mix rerun is stored in a sanitized, covered stainless steel container and used the following day. **DO NOT prime the machine with rerun.** When using rerun, skim off the foam and discard. Mix the rerun with fresh mix in a ratio of 50/50 during the days operation.

- 6. On a designated day of the week, run the mix as low as feasible and discard it after closing. This will break the rerun cycle and reduce the possibility of high bacteria and coliform counts.
- 7. Properly prepare the cleaning and sanitizing solutions. Read and follow label directions carefully. Too strong of a solution may damage the parts and too weak of a solution will not do an adequate job of cleaning or sanitizing.
- 8. The temperature of the mix in the mix hopper and walk-in cooler should be below 40°F (4.4°C).

Regular Maintenance Checks

- 1. Replace scraper blades that are nicked or damaged. Before installing the beater assembly, be certain that scraper blades are properly attached to the helix.
- 2. Check the rear shell bearing for signs of wear (excessive mix leakage in rear drip pan) and be certain it is properly cleaned.
- 3. Using a screwdriver and cloth towel, keep the rear shell bearing and the female hex drive socket clean and free of lubricant and mix deposits.
- 4. Dispose of o-rings and seals if they are worn, torn, or fit too loosely, and replace with new ones.
- 5. Follow all lubricating procedures as outlined in “Assembly”.

- 6. If your machine is air cooled, check the condensers for accumulation of dirt and lint. Dirty condensers will reduce the efficiency and capacity of the machine. Condensers should be cleaned **monthly** with a soft brush. **Never** use screwdrivers or other metal probes to clean between the fins.

Note: For machines equipped with an air filter, it will be necessary to vacuum clean the filters on a monthly schedule.



Caution: Always disconnect electrical power prior to cleaning the condenser. Failure to follow this instruction may result in electrocution.

- 7. If your machine is equipped with an auxiliary refrigeration system, check the auxiliary condenser for accumulation of dirt and lint. Dirty condensers will reduce the refrigeration capacity of the mix hopper. Condensers must be cleaned **monthly** with a soft brush. **Never** use screwdrivers or other metal probes to clean between the fins.



Caution: Always disconnect electrical power prior to cleaning the condenser. Failure to follow this instruction may result in electrocution.

- 8. If your machine is water cooled, check the water lines for kinks or leaks. Kinks can occur when the machine is moved back and forth for cleaning or maintenance purposes. Deteriorated or cracked water lines should be replaced only by an authorized Taylor distributor.

Winter Storage

If the place of business is to be closed during the winter months, it is important to protect the freezer by following certain precautions, particularly if the building is subject to freezing conditions.

Disconnect the freezer from the main power source to prevent possible electrical damage.

On water cooled freezers, disconnect the water supply. Relieve pressure on the spring in the water valve. Use air pressure on the outlet side to blow out any water remaining in the condenser. **This is extremely important.** Failure to follow this procedure may cause severe and costly damage to the refrigeration system.

Your local Taylor Distributor can perform this winter storage service for you.

Wrap detachable parts of the freezer such as beater, blades, drive shaft, and freezer door, and place them in a protected dry place. Rubber trim parts and gaskets can be protected by wrapping them with moisture-proof paper. All parts should be thoroughly cleaned of dried mix or lubrication which attract mice and other vermin.

Section 8

Troubleshooting Guide

PROBLEM	PROBABLE CAUSE	REMEDY	PAGE REF.
1. No product is being dispensed with draw valve open and the machine in the AUTO mode.	a. Freeze-up in mix inlet hole.	a. Call service technician to adjust the mix hopper temperature.	---
	b. Beater motor out on reset.	b. Reset the freezer.	12
	c. The beater is rotating counterclockwise from the operator end.	c. Contact service technician to correct rotation to clockwise from operator end.	---
	d. The circuit breaker is off or the fuse is blown.	d. Turn the breaker on, or replace the fuse.	---
	e. There is inadequate mix in the mix hopper.	e. Fill the mix hopper with mix.	20
2. The product is too stiff.	a. The viscosity needs adjustment.	a. Contact service technician.	---
3. The product is too soft.	a. Viscosity needs adjustment.	a. Contact service technician.	---
	b. Not enough air space around unit. (Air cooled units)	b. Allow for adequate air flow across the condenser.	1/ 6
	c. Worn scraper blades.	c. Replace regularly.	27
	d. Dirty condenser (A/C)	d. Clean monthly.	24
	e. Mix is out of date.	e. Use only fresh mix.	---
	f. Loss of water. (W/C)	f. Locate cause of water loss and correct.	24
4. The mix in the mix hopper is too cold.	a. The temperature is out of adjustment.	a. Call service technician to adjust the mix hopper temperature.	---
5. The mix in the mix hopper is too warm.	a. The temperature is out of adjustment.	a. Call service technician to adjust the mix hopper temperature.	---
	b. The mix hopper cover is not in position.	b. Place the cover in position.	20
	c. The MIX REF light is not lit.	c. Press the MIX REF key.	11

PROBLEM	PROBABLE CAUSE	REMEDY	PAGE REF.
6. The drive shaft is stuck in the drive coupling.	a. Rounded corners of drive shaft, coupling, or both.	a. Call service technician to correct cause, and to replace the necessary components. Do not lubricate the hex end of the drive shaft.	---
	b. Mix and lubricant collected in the drive coupling.	b. Brush clean the rear shell bearing area regularly.	22
7. The freezing cylinder walls are scored.	a. The beater assembly is bent.	a. Call service technician to repair or replace the beater and to correct the cause of insufficient mix in the freezing cylinder.	---
	b. The front bearing is missing or worn on the freezer door.	b. Install or replace the front bearing.	15
8. Excessive mix leakage into the rear drip pan.	a. Missing or worn drive shaft seal on drive shaft.	a. Install or replace regularly.	14 / 27
	b. The rear shell bearing is worn.	b. Call service technician to replace rear shell bearing.	---
9. Excessive mix leakage from door spout.	a. Missing or worn draw valve o-rings.	a. Install or replace regularly.	16 / 27
	b. Inadequate lubrication of draw valve o-rings.	b. Lubricate properly.	16
	c. Wrong type of lubricant is being used (example: petroleum base lubricant).	c. Use the proper lubricant (example: Taylor Lube).	14
10. No freezer operation after pressing the AUTO key.	a. Unit is unplugged.	a. Plug into wall receptacle.	---
	b. The circuit breaker is off or the fuse is blown.	b. Turn the breaker on, or replace the fuse.	---
	c. The beater motor is out on reset.	c. Reset the freezer.	12
11. Product is not feeding into the freezing cylinder.	a. Inadequate level of mix in the mix hopper.	a. Fill the mix hopper with mix.	20
	b. The mix inlet hole is frozen up.	b. The mix hopper temperature needs adjustment. Call service technician.	---

Section 9

Parts Replacement Schedule

PART DESCRIPTION	EVERY 3 MONTHS	EVERY 6 MONTHS	ANNUALLY
Drive Shaft Seal	X		
Scraper Blade	X		
Freezer Door Gasket	X		
Front Bearing	X		
Draw Valve O-Ring	X		
Prime Plug O-Ring	X		
Feed Tube O-Ring	X		
Air Orifice O-Ring	X		
White Bristle Brush, 3" x 7"		Inspect & Replace if Necessary	Minimum
White Bristle Brush, 1" x 2"		Inspect & Replace if Necessary	Minimum
Black Bristle Brush, 1" x 2"		Inspect & Replace if Necessary	Minimum
Double-Ended Brush		Inspect & Replace if Necessary	Minimum
White Bristle Brush, 1/2" x 1/2"		Inspect & Replace if Necessary	Minimum
White Bristle Brush, 3/16" x 1"		Inspect & Replace if Necessary	Minimum
White Bristle Brush, 3" x 1/2"		Inspect & Replace if Necessary	Minimum

Section 10

Parts List

DESCRIPTION	PART NUMBER	C707 QTY.	WARR. CLASS	REMARKS
BEARING-FRONT	050216	1	000	
BEARING-REAR SHELL *NICK.PLATE	031324	1	000	
+GUIDE-DRIP SEAL	028992	1	000	
+NUT-BRASS BEARING	028991	1	000	
+O-RING-1/2OD X .070W	024278	2	000	
+WASHER-BEARING LOCK	012864	1	000	
BEATER A-3.4QT-HELICORE	X31761	1	103	
+BLADE-SCRAPER-PLASTIC 17L	035174	2	000	
BELT-AX41	023876	2	000	208-230V 60HZ 1PH - 208-230V 60HZ 3PH
BLOCK-TERMINAL 2P-L1,L2	039422	1	103	208-230V 60HZ 1PH
BLOCK-TERMINAL 3P-L1,L2,L3	039423	1	103	208-230V 60HZ 3PH
BOARD-LOGIC-GEN 2.10-W/SEL DI	X36641SER2	1	212	REPLACES X36641SER1
BRUSH-REAR BRG 1IN.DX2IN.LGX14	013071	1	000	
BRUSH-DOUBLE ENDED-PUMP&FEED T	013072	1	000	
BRUSH-DRAW VALVE 1"ODX2"X17"L	013073	1	000	
BRUSH-END-DOOR-SPOUT-SS-HT	039719	1	000	
BRUSH-MIX PUMP BODY-3"X7"WHITE	023316	1	000	
BRUSH-SET LVB	050103	1	000	
BRUSH-PUMP SPOUT *MC13*	054068	1	000	
CABLE-RIBBON-PWR/RLY*C706* 60"	056295	1	103	
COMPRESSOR L64A113BBCA	048259-27E	1	512	208-230V 60HZ 1PH - BRISTOL K7026650 & UP
+CAPACITOR-START 189-227UF/330V	033044-1	1	103	
+CAPACITOR-RUN 25UF/440V	037431	1	103	
+RELAY-START-COMPRESSOR	062363	1	103	
+GROMMET-COMPRESSOR MOUNT-AH	039923	4	000	
+SLEEVE-MOUNTING-COMP .AH	039924	4	000	
COMPRESSOR AHA2490ZXD-AH556EF	047519-27F	1	512	208-230V 60HZ 1PH, TECUMSEH K7015617 & PRIOR
+CAPACITOR-RUN- 35UF/440V	048132	1	103	
+CAPACITOR-START-130-156UF/330V	036048	1	103	
+RELAY-START-COMPRESSOR	036047	1	103	
COMPRESSOR L63A113DBLA	048259-33	1	512	208-230V 60HZ 3PH, K7026650 - BRISTOL
COMPRESSOR AHA2490ZXF-AH556RF	047519-33F	1	512	208-230V 60HZ 3PH, K7015617/PRIOR - TECUMSEH

+ Available Separately

DESCRIPTION	PART NUMBER	C707 QTY.	WARR. CLASS	REMARKS
COMPRESSOR PL35G	055187-27	1	512	SHR
+RELAY-START-COMPRESSOR	055358	1	103	
+CAPACITOR-START 60UF-220/275	047703	1	103	
CONDENSER-AC-15LX14HX2.59T-3RW	046558	1	103	MAIN REFRIGERATION
CONDENSER-AC-7X6X1.25-2 ROW	027155	1	103	SHR
COUPLING-DRIVE 3/4 HEX X 1-7/8	012721	1	103	
COVER-CONTROL BOX	064111-SP1	1		
COVER-HOPPER COMPLETE (Black)	053809-1	1	103	K2010000/up USING BLACK COVER U/D 167
+PIN-RETAINING-HOPPER COVER	043934	4	103	U/D 167
DECAL-DEC-TAYLOR C707	057312	1	000	
DECAL-INST-CLN HPR	019029	1	000	
DECAL-TROUBLESHOOT	038374	1	000	
DIAGRAM-WIRING *C706*C707*	064288-27	1	000	208-230V 60HZ 1PH, K7026650 & UP - BRISTOL
DIAGRAM-WIRING *C706*C707*	064288-33	1	000	208-230V 60HZ 3PH, K7026650 & UP - BRISTOL
DIAGRAM-WIRING *C706*C707*	056352-27	1	000	208-230V 60HZ 1PH, K7015617/PRIOR - TECUMSEH
DIAGRAM-WIRING *C706*C707*	056352-33	1	000	208-230V 60HZ 3PH, K7015617/PRIOR - TECUMSEH
DOOR A.-W/BAFFLE *C706*	X56071-SER	1	103	
+HANDLE A.-DRAW-WELDED *C706*	X56246	1	103	
+SCREW-ADJUSTMENT-5/16-24 *602*	056332	1	103	
+O-RING-1/4 OD X .070W 50 DURO	015872	1	000	
+GASKET-DOOR HT 4"	048926	1	000	
+PIN-HANDLE-SS *C602*	055819	1	103	
+PLUG-PRIME	028805	1	103	
+O-RING-3/8 OD X .070W	016137	2	000	
+VALVE A.-DRAW *C706*	X56072	1	103	
+O-RING-7/8 OD X .103W	014402	3	000	
DRYER-CAP. TUBE .021 ID X 9FT	055522	1	000	
DRYER-FILTER-HP62-3/8 X 1/4S	048901	1	000	
GASKET-BASE PAN *C706*	056058	1	000	
GEAR A. *REDUCER 4.21:1	021286-SER	1	212	
GUARD-FAN	028534-1	1	103	SHR
GUIDE A.-DRIP PAN	X28863	1	103	REAR SHELL BEARING - LONG
HARNES-WIRE *C706*BEATER MTR	056328-27G	1	103	208-230V 60HZ 1PH

+ Available Separately

DESCRIPTION	PART NUMBER	C707 QTY.	WARR. CLASS	REMARKS
HARNES-WIRE *C706*BEATER MTR	056328-33G	1	103	208-230V 60HZ 3PH
JACK A.-FLAVORBURST *C706*	X56353	1	103	
KIT-MOUNTING-COMPRESSOR	047704	1	000	
KIT A.-MOTOR-FAN	X62253-27	1	103	AUX - FAN MOTOR KIT
+GUARD-FAN	028534-1	1	103	SHR
+SHROUD-DANFOSS	027386	1	103	SHR
KIT A.-TUNE UP *1SPOUT*	X49463-58	1	000	
BEARING-FRONT	050216	1	000	
GASKET-DOOR HT 4"-DOUBLE	048926	1	000	
O-RING-1/4 OD X .070W 50 DURO	015872	1	000	
O-RING-3/8 OD X .070W	016137	2	000	
O-RING-7/8 OD X .103W	014402	3	000	
SEAL-DRIVE SHAFT	032560	1	000	
TOOL-O-RING REMOVAL-FREEZER	048260-WHT	1	000	
LABEL-CAUTION-GRD-PERM-ENG/SP	032164	1	000	
LABEL-DOOR-MOVE PART	032749	1	000	
LABEL-SW-POWER-OFF/ON-SYMBOLS	052632	1	000	
LABEL-WARN-COVER	051433	4	000	OUTSIDE PANELS
LUBRICANT-TAYLOR 4 OZ.	047518	1	000	
MAN-OPER C707	059060-M	1	000	
MOTOR-1.5 HP	021522-27	1	212	208-230V 60HZ 1PH
MOTOR-1.5 HP	021522-33	1	212	208-230V 60HZ 3PH
MOTOR A.-FAN 92 WATT 1630 RP	064003-27	1	103	K7026650 & UP - BRISTOL - MAIN CONDENSER
+BOOT-CAPACITOR-INSUL 1.75" D	062452	1		
+CAPACITOR-RUN 2UF 450 VAC	064004	1	103	
MOTOR-FAN 80 WATT 1550 RPM CW	051744-27	1	103	208-230V 60HZ 1PH, K7015617/PRIOR - TECUMSEH
+BOOT-CAPACITOR INSULATING	031314	1	000	
+FAN-5 BLADE 12" PUSH 32DEG CCW	047279	1	103	
+CAPACITOR-RUN- 4UF-440V	051785	1	103	
MOTOR-FAN 95.3 CFM 2700 RPM		*		USE X62253-27 KIT - AUX SYSTEM
NUT-STUD-BLACK 2.563 LONG	058764	2	103	K3060000/UP
NUT-STUD-BLACK 3.250 LONG	058765	2	103	K3060000/UP
ORIFICE	022465-100	1	103	

+ Available Separately

DESCRIPTION	PART NUMBER	C707 QTY.	WARR. CLASS	REMARKS
+O-RING-3/8 OD X .070W	016137	1	000	
PAIL-MIX 10 QT.	013163	1	000	
PAN-DRIP 11-5/8 LONG	027503	1	103	SIDE PANEL
PANEL A.-FRONT-UPPER *C706*	X58950	1	103	
PANEL-FRONT-LOWER *C706*	058942	1	103	
PANEL A.-SIDE-RIGHTC706/C707AC	X64151	1	103	
PANEL-SIDE-LEFT *C707*	056082-SP3	1	103	
PANEL-REAR *C707*	056077-SP1	1	103	
PANEL A.-SIDE-RIGHT *C706*	X65441	*	103	TOP AIR DISCHARGE-HI CAP
PLUG-DRIP PAN HOLE	029595	1	103	
PROBE A.-MIX *SQUARE*	X30922	1	103	MIX LOW
+DISC-PROBE *SQ HOLE*	030965	1	103	
+SPACER-PROBE *SQ HOLE*	030966	1	103	
PROBE A.-MIX OUT-SQUARE HOLE	X41348	1	103	MIX OUT
+SPACER-PROBE-ROUND HOLE-5/8DIA	041347	1	103	
+SPACER-PROBE-SQUARE HOLE-7/8	041346	1	103	
PROBE A.-THERMISTOR	X31602	1	103	BARREL
PROBE A.-THERMISTOR/RESISTOR	X50717	1	103	HOPPER
PULLEY-2AK22 X .625-.6265	016403	1	103	208-230V 60HZ 1PH - 60HZ BEATER MOTOR
PULLEY-2AK74-5/8	027822	1	103	GEAR
RECEPTACLE A.-QUICK CONNECT	X33321	1	103	DRAW SWITCH
RELAY-3 POLE-20A-208/240 50/60	066795-33	1	103	REPLACES 012725-33
SANITIZER-STERA SHEEN GR.	010425	1	000	64 OZ JAR
SANITIZER-STERA SHEEN -GREEN	055492	1	000	100/20Z. PACKETS/CS
SHAFT-BEATER *C706*	056078	1	103	
+SEAL-DRIVE SHAFT	032560	1	000	
SHELF-TRAY-DRIP *C706*	056076	1	103	
SHELL A.-INSULATED *C707*	X64133-SER	1	512	
+STUD-NOSE CONE *C602*	055987	4	103	
SHIELD-SPLASH *RD30*	049203	1	103	
SHROUD-DANFOSS	027386	1	103	SHR
SHROUD A.-COND. *C706/C707*AC*	X64127	1	103	MAIN CONDENSER
STARTER-1 PHASE 6.3 TO 10 AMP	066794-27K	1	103	208-230 V 60HZ 1PH - REPLACES 041950-27K

+ Available Separately

DESCRIPTION	PART NUMBER	C707 QTY.	WARR. CLASS	REMARKS
STARTER-3 PHASE 4 TO 6.5 AMP	066794-33J	1	103	208-230V 60HZ 3PH - REPLACES 041950-33J
SWITCH A.-DRAW *C706*	X56147	1	103	
ARM A.-DRAW *C706*	X56253	1	103	
E-RING 3/16 .335 O.D.	049178	1	000	
PIN-PIVOT	015478	1	103	
SPRING-RETURN-LEFT-SELF CLOSE	041660	1	103	
SPRING-RETURN-RIGHT-SELF CLOSE	041661	1	103	
SWITCH-LEVER-SPDT-10A-125-250V	028889	2	103	
SWITCH-PRESSURE 440 PSI-SOLDER	048230	1	103	K7026650 & UP - BRISTOL
SWITCH-PRESSURE 405 PSI-SOLDER	052663	1	103	K7015187 & PRIOR - TECUMSEH
SWITCH-REED*DOOR INTERLOCK*68"	056771	1	103	
SWITCH-TOGGLE-DPDT*ON-NONE-ON	024295	1	103	
THERMOMETER-DIGITAL *C706*	056239	1	103	
TOOL-O-RING REMOVAL-FREEZER	048260-WHT	1	000	
TRAY-DRIP-SOFT SERVE *C706*	056858	1	103	
TRIM-CORNER-REAR-LEFT *C706*	056964	1	103	
TRIM-CORNER-REAR-RIGHT *C706*	056965	1	103	
TUBE A.-FEED-SS-5/32 HOLE DIA	X29429-2	1	103	
+O-RING-.643 OD X .077W	018572	4	000	
VALVE-ACCESS 1/4FL X 1/4SOLDER	044404	1	103	
VALVE-ACCESS-1/4 MFLX1/4 S-90	047016	1	103	SHR
VALVE-ACCESS-1/4MFL X 3/8ODSDR	053565	2	103	TECUMSEH K7015187 & PRIOR
VALVE-EPR 1/4S	022665	1	103	
VALVE-EXP-AUTO-1/4S X1/4 FPT	046365	1	103	
+BOOT-EXPANSION VALVE	050900	1	000	
WASHER-PLASTIC PIVOT	013808	4	000	
WATER COOLED				
CONDENSER-WC-SPIRAL 11-1/2 O	049309	1	103	
COUPLING-3/8 NPT BLACK PIPE	010878	1	103	
CLAMP-HOSE-ADJ 7/16 X 25/32	010031	4	000	
MOTOR A.-FAN *C706* WC	X56435-27	1	103	
MOTOR-FAN-25W 230V	015184-27	1	103	

+ Available Separately

DESCRIPTION	PART NUMBER	C707 QTY.	WARR. CLASS	REMARKS
BRACKET-FAN *453/750*	038641	1	103	
+FAN-5 BLADE 10 " PUSH	013043	1	103	
PANEL-REAR *C707/9* WC	056077-SP4	1	103	
PANEL-SIDE-RIGHT *C706/C707*	064148	1	103	
VALVE A.-WATER *C706/C707*WC	X64146	1	103	
ADAPTOR-3/8MP X 1/2 BARB-BR	011021	2	103	
BRACKET A.-FITTING*C706/C707	X64145	1	103	
CLAMP-HOSE-ADJ 7/16 X 25/32	010031	2	103	
HOSE-RUBBER 1/2"ID X 7/8"OD	020901-21	1	000	
HOSE-RUBBER 1/2"ID X 7/8"OD	020901-22	1	000	
NIPPLE-3/8 X 3-1/2 GALV	016768	1	103	
SWITCH-PRESSURE 350 PSI-S	048231	1	103	
VALVE-WATER 3/8 REG/HEAD PRESS	046686	1	103	
INTERNATIONAL SPECIFICATIONS				
BELT-AX42	023877	2	000	220-240V 50HZ 1PH - 220/380V 60HZ 3PH-4 WIRE - 380-415V 50HZ 3N~ 460V 60HZ 3PH
BLOCK-TERMINAL 2P L1,N	039421	1	103	220-240V 50HZ 1PH
BLOCK-TERMINAL 7P GREEN	024156	1	103	220-240V 50HZ 1PH - 380-415V 50HZ 3N~
BLOCK-TERMINAL 4P L1,L2,L	039424	1	103	220/380V 60HZ 3PH-4 WIRE - 380-415V 50HZ 3N~
BLOCK-TERMINAL 3P L1,L2,L	039423	1	103	200V 50/60HZ 3PH - 460V 60HZ 3PH
COMPRESSOR L63A113BBKA	048259-40	1	512	220-240V 50HZ 1PH - BRISTOL - C706-40 - S/N K8102144 & UP
+CAPACITOR-RUN 25UF/370VAC	023739	1	103	
+CAPACITOR-START 161-193UF/25	031790	1	103	
+RELAY-START-COMPRESSOR	038146	1	103	
COMPRESSOR FH2511Z	054476-40	1	512	220-240V 50HZ 1PH - TECUMSEH C706-40
+CAPACITOR-RUN- 25 UF/440V	037431	1	103	
+CAPACITOR-START-145-175UF/330V	054824	1	103	
+RELAY-START-COMPRESSOR	054823-40	1	103	
COMPRESSOR L63A113DBEA	048259-58	1	512	380-415V 50HZ 3N~ C706-58
COMPRESSOR AHA2490ZXG-AH556TF	047519-62F	1	512	380-415V 50HZ 3N~ - 220/380V 60HZ 3PH-4 WIRE -460V 60HZ 3PH - BRISTOL - C706-58

+ Available Separately

DESCRIPTION	PART NUMBER	C707 QTY.	WARR. CLASS	REMARKS
11/12/02 TO 12/04/06				
DIAGRAM-WIRING *C706*C707*	064288-40	1	000	220-240V 50HZ 1PH
DIAGRAM-WIRING *C706*C707*	064288-58	1	000	380-415V 50HZ 3N~
DIAGRAM-WIRING *C706*C707*	064288-63	1	000	460V 60HZ 3PH
FUSE-4 AMP-600 VOLT	051194	1	000	460V 60HZ 3PH
+HOLDER-FUSE 600 VOLT PANEL M	051195	1	103	460V 60HZ 3PH
HARNESS-WIRE *C706*BEATER MTR	056328-33G	1	103	220/380V 60HZ 3PH-4 WIRE - 380-415V 50HZ 3N-- - 460V 60HZ 3PH
HARNESS-WIRE-SOL-LIQ C706/C707	064155-G	1	103	220-240V 50HZ 1PH - 380-415V 50HZ 3N~
LABEL-CK MTR ROTATE-CW-EN	020090	1	000	380-415V 50HZ 3N~ - 460V 60HZ 3PH
MOTOR-1.5 HP	021522-33	1	212	200V 50/60HZ 3PH - 460V 60HZ 3PH
MOTOR-1.5 HP CAPS@10&2 O'CLOCK	021522-34	1	212	220-240V 50HZ 1PH
MOTOR-1.5 HP	021522-35	1	212	380-415V 50HZ 3N~
PULLEY-2AK27 X .625-.6265	011545	1	103	220-240V 50HZ 1PH / 380-415V 50HZ 3N~
RELAY-SPST-30 A-240 V	032607-27	1	103	460V 60HZ 3PH
STARTER-1 PHASE-4.5 TO 7 A	041950-27K	1	103	220-240V 50HZ 1PH
STARTER-3 PHASE-2.0 TO 3.	041950-33H	1	103	220/380V 60HZ 3PH-4 WIRE - 380-415V 50HZ 3N-- - 460V 60HZ 3PH

+ Available Separately

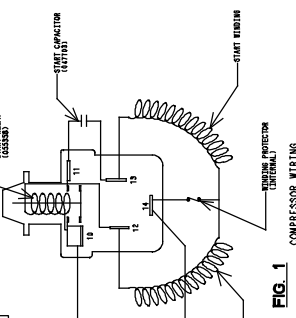
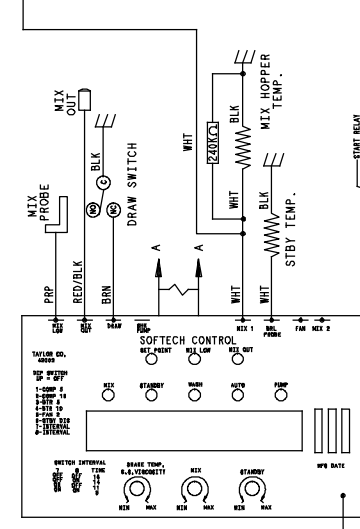
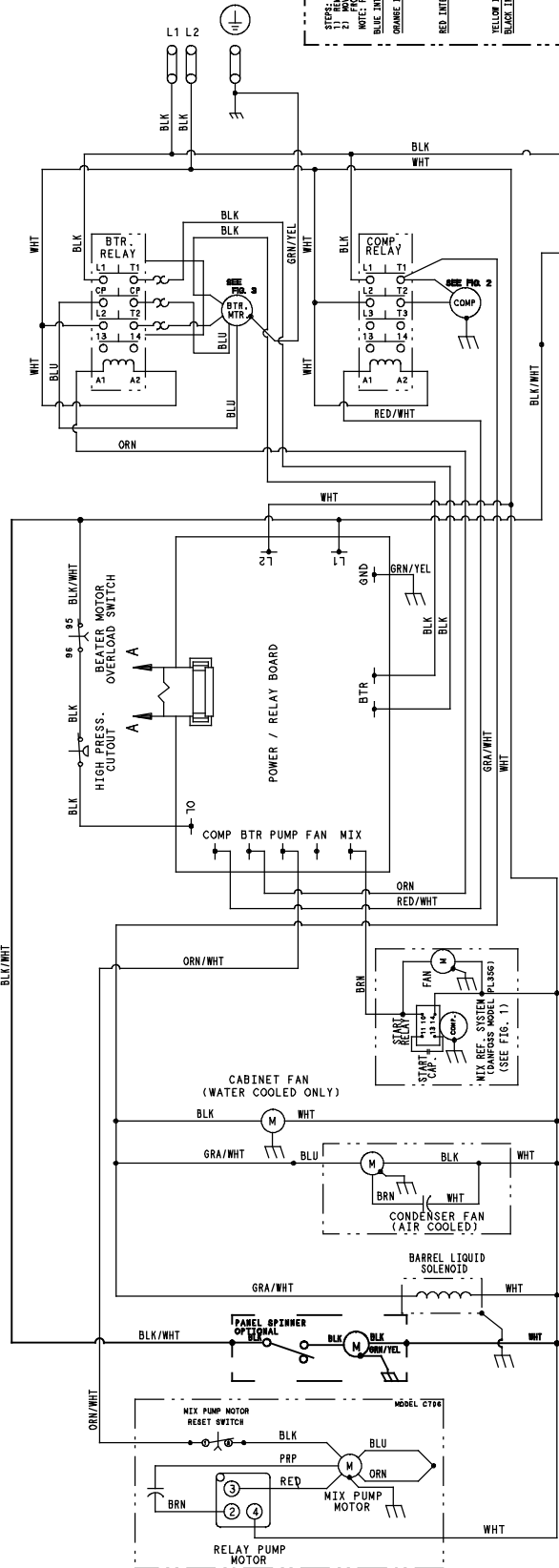

FIG. 1

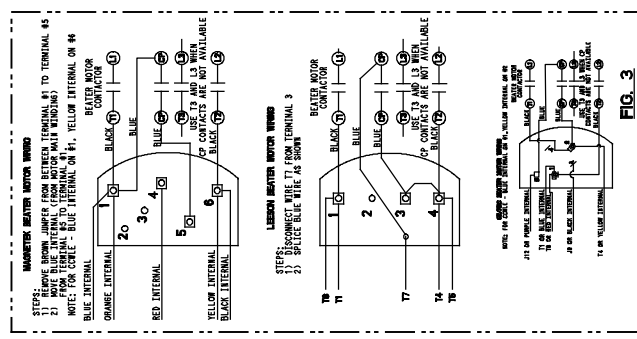
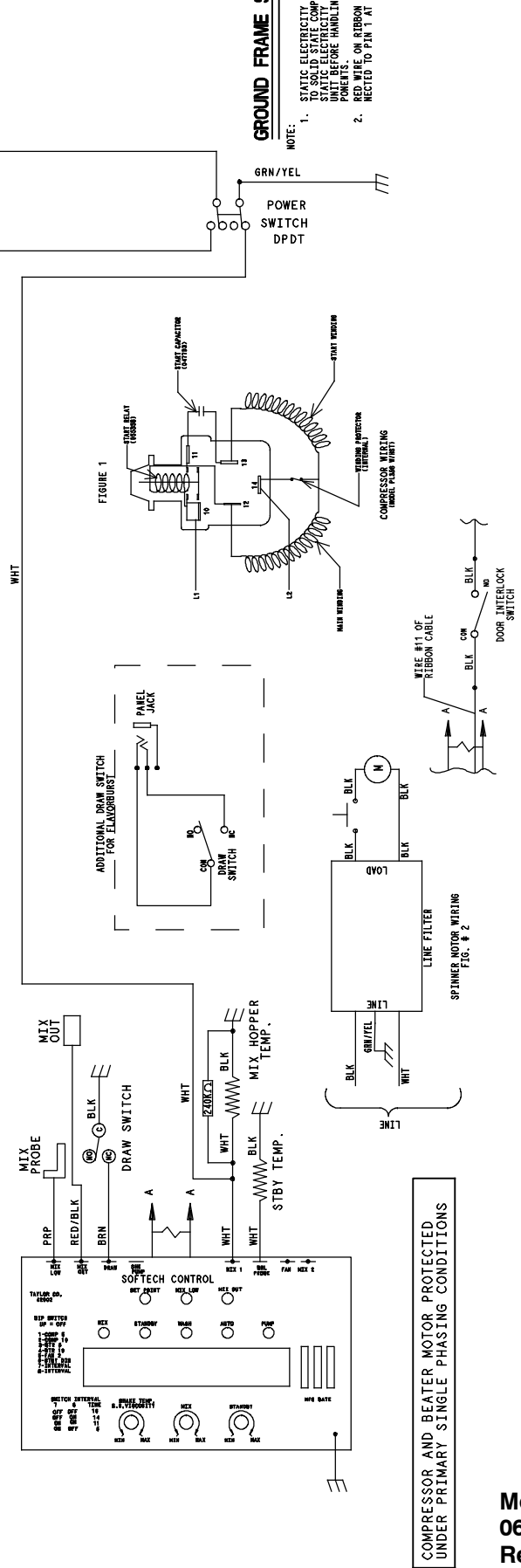
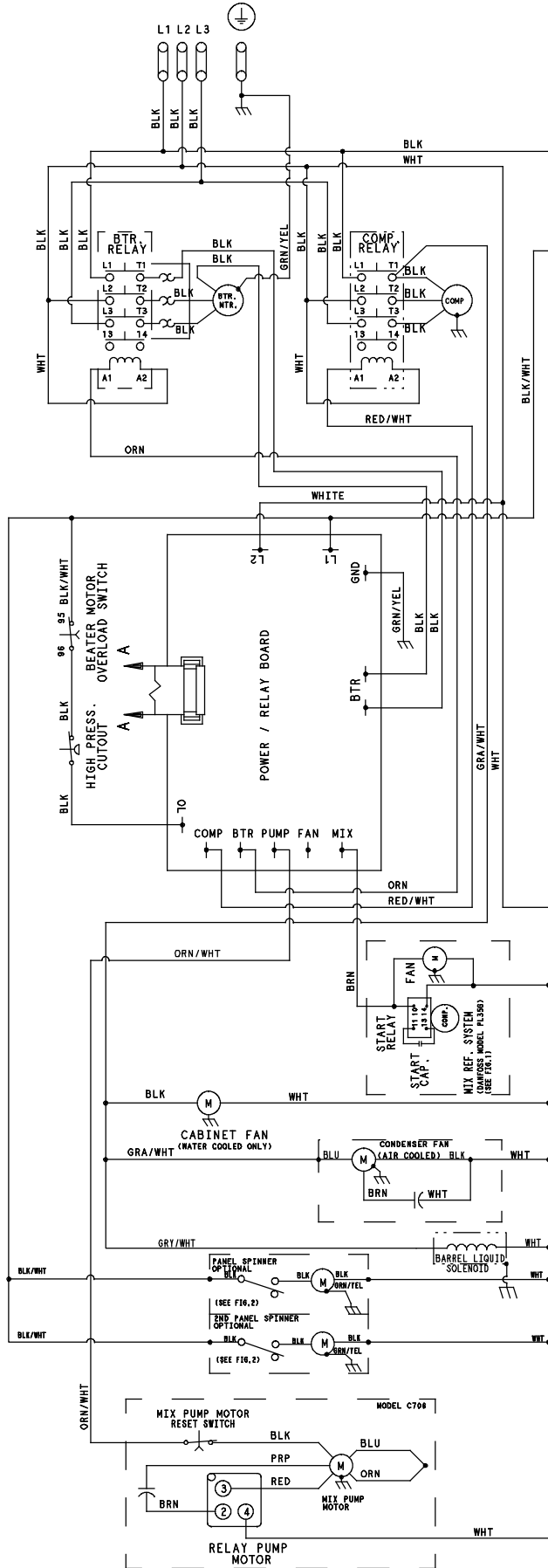

FIG. 3

GROUND FRAME SECURELY

NOTE:

1. STATIC ELECTRICITY MAY CAUSE DAMAGE TO THE CONTROL SYSTEM. DISCHARGE STATIC ELECTRICITY BY TOUCHING GROUND-POINTS BEFORE HANDLING SOLID STATE COMPONENTS.
2. ON STRIPON CABLES MUST BE CONNECTED TO PIN 1 AT EACH END.



GROUND FRAME SECURELY

- NOTE:
1. STATIC ELECTRICITY MAY CAUSE DAMAGE TO THE COMPRESSOR. DISCHARGE STATIC ELECTRICITY BY TOUCHING GROUNDING POINTS BEFORE HANDLING SOLID STATE COMPONENTS. ON RUBBER CABLES, MUST BE CONNECTED TO PIN 1 AT EACH END.

COMPRESSOR AND BEATER MOTOR PROTECTED UNDER PRIMARY SINGLE PHASING CONDITIONS

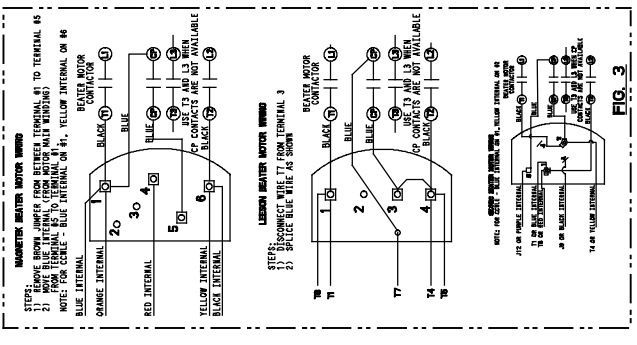
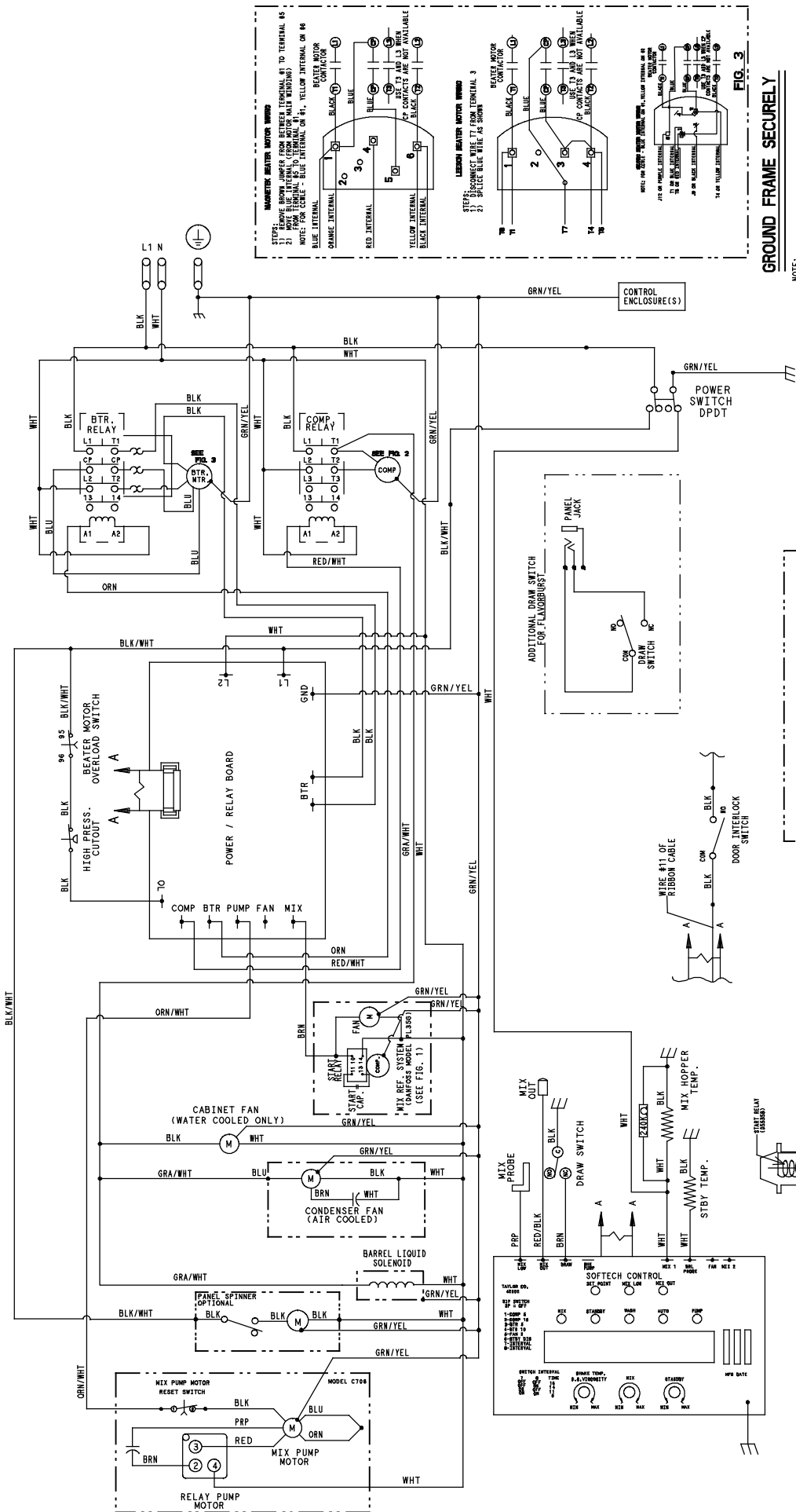

GROUND FRAME SECURELY

- NOTE:
1. STATIC ELECTRICITY MAY CAUSE DAMAGE TO THE CONTROL BOARD. DISCHARGE STATIC ELECTRICITY BY TOUCHING GROUND-POINTS BEFORE HANDLING SOLID STATE COMPONENTS. ON STRIPBORN CABLES MUST BE CONNECTED TO PIN 1 AT EACH END.

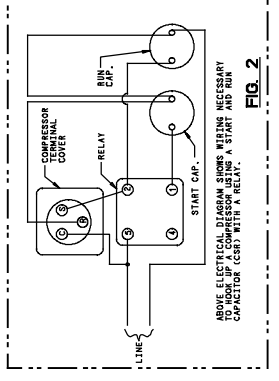

ABOVE ELECTRICAL DIAGRAM SHOWS WIRING NECESSARY TO START AND RUN COMPRESSOR (C67) WITH A RELAY.

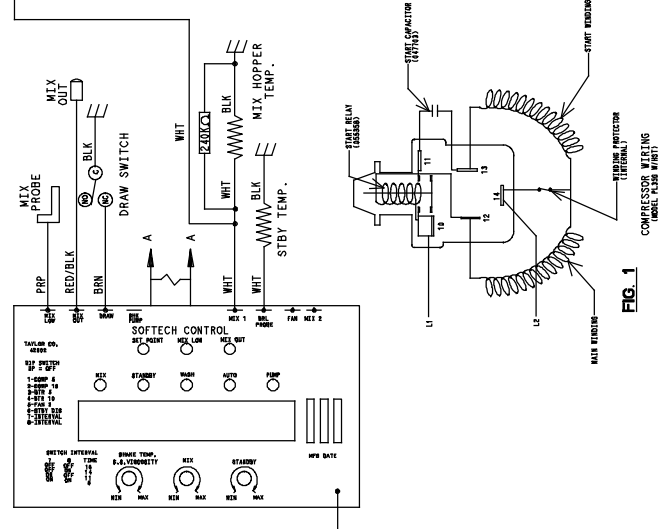
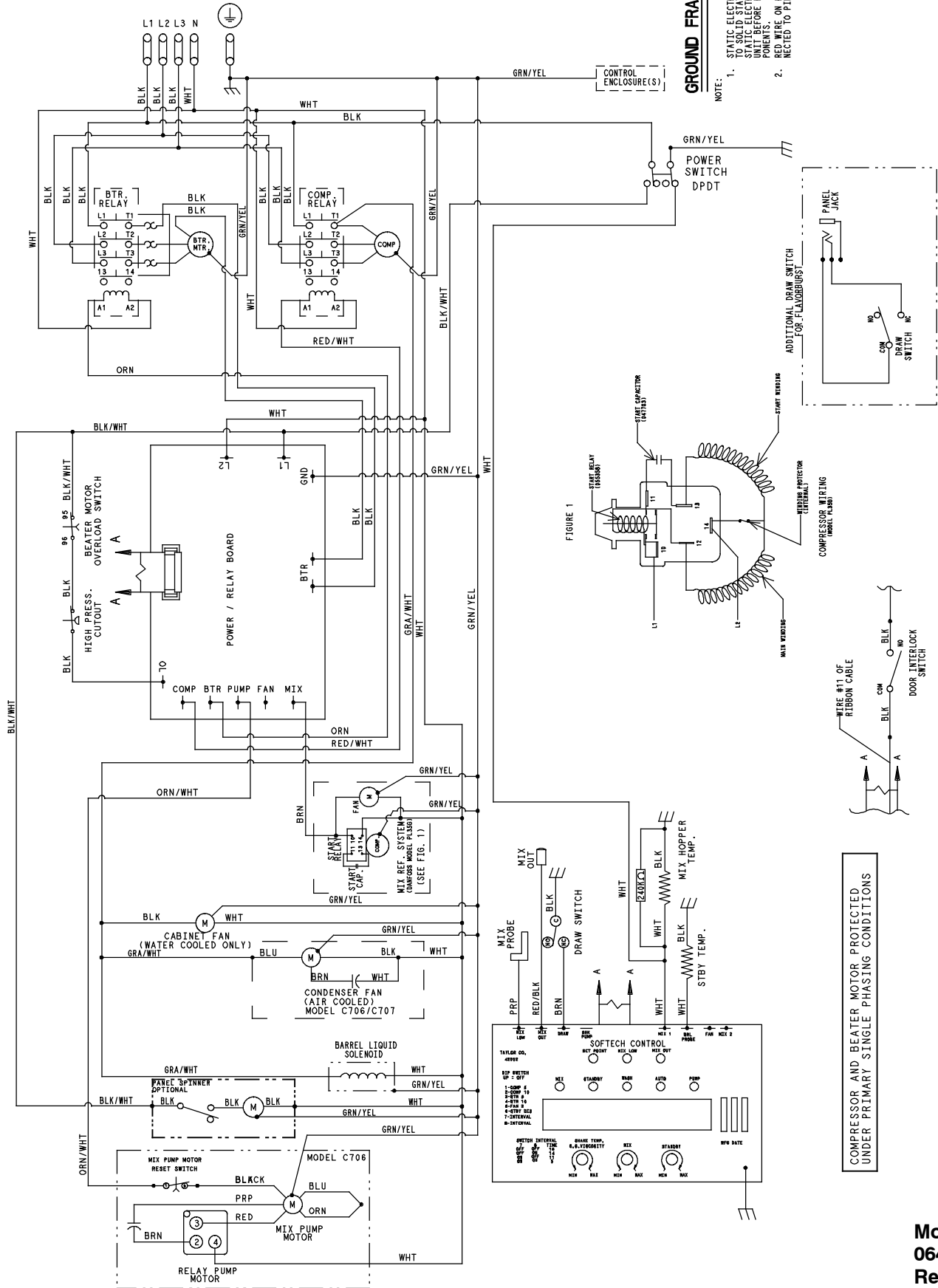

FIG. 1



GROUND FRAME SECURELY

- NOTE:
1. STATIC ELECTRICITY MAY CAUSE DAMAGE TO SOLID STATE COMPONENTS. - ELIMINATE STATIC ELECTRICITY BY TOUCHING GROUNDED POINTS BEFORE HANDLING SOLID STATE COMPONENTS.
 2. RED WIRE ON RIBBON CABLES MUST BE CONNECTED TO PIN 1 AT EACH END.

FIGURE 1

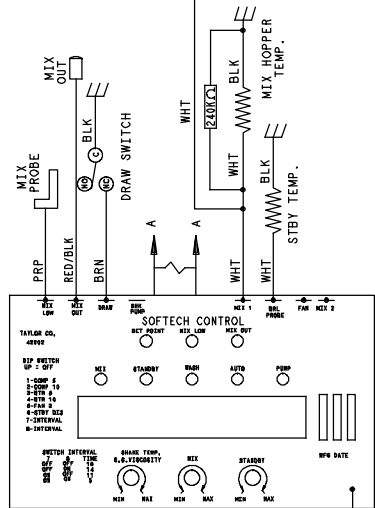
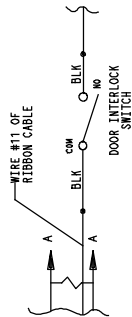
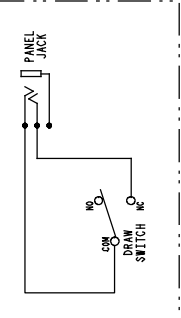
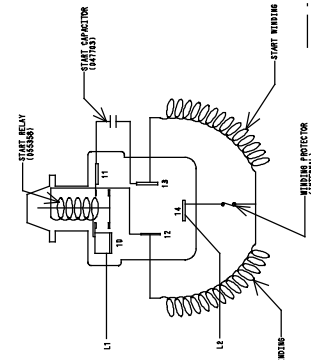

COMPRESSOR AND BEATER MOTOR PROTECTED UNDER PRIMARY SINGLE PHASING CONDITIONS