

Model 142

Little Softy Soft Serve Freezer

Original Operating Instructions

039709-M



**3/00 (Original Publication)
(Updated 5/1/12)**

Complete this page for quick reference when service is required:

Taylor Distributor: _____

Address: _____

Phone: _____

Service: _____

Parts: _____

Date of Installation: _____

Information found on the data label:

Model Number: _____

Serial Number: _____

Electrical Specs: Voltage _____ Cycle _____

Phase _____

Maximum Fuse Size: _____ A

Minimum Wire Ampacity: _____ A

© March, 2000 Taylor
All rights reserved.
039709-M



*The word Taylor and the Crown design
are registered trademarks in the United States
of America and certain other countries.*

Taylor Company
750 N. Blackhawk Blvd.
Rockton, IL 61072

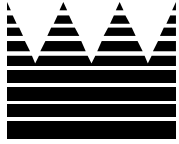

Table of Contents

| | | |
|------------------|--|----|
| Section 1 | To the Installer | 1 |
| | Installer Safety | 1 |
| | Site Preparation | 1 |
| | Air Cooled Units | 1 |
| | Electrical Connections | 2 |
| | Electrical Hook-up Installation For 60 Cycle, 1 PH, Supplied With Cord and Plug | 3 |
| | Refrigerant | 3 |
| Section 2 | To the Operator | 4 |
| Section 3 | Safety | 5 |
| Section 4 | Operator Parts Identification | 7 |
| Section 5 | Important: To the Operator | 8 |
| | Symbol Definitions | 8 |
| | Power Switch | 8 |
| | Indicator Light - MIX LOW | 9 |
| | Standby Switch | 9 |
| | Reset Mechanism | 9 |
| | Temperature Adjustments | 9 |
| | Feed Tube | 9 |
| Section 6 | Operating Procedures | 10 |
| | Assembly | 10 |
| | Sanitizing | 13 |
| | Priming | 15 |
| | Standby | 16 |
| | Closing Procedure | 16 |
| | Draining Product From the Freezing Cylinder | 16 |

| | |
|--|-----------|
| Rinsing | 16 |
| Cleaning | 17 |
| Disassembly | 17 |
| Brush Cleaning | 17 |
| Section 7 Important: Operator Checklist | 19 |
| During Cleaning and Sanitizing: | 19 |
| Troubleshooting Bacterial Count: | 19 |
| Regular Maintenance Checks: | 19 |
| Winter Storage | 20 |
| Section 8 Troubleshooting Guide | 21 |
| Section 9 Parts Replacement Schedule | 23 |
| Section 10 Parts List | 24 |
| Wiring Diagram | 30 |

Note: Continuing research results in steady improvements; therefore, information in this manual is subject to change without notice.

Note: Only instructions originating from the factory or its authorized translation representative(s) are considered to be the original set of instructions.

© March, 2000 Taylor (Original Publication)
(Updated May, 2012)
All rights reserved.
039709-M



*The word Taylor and the Crown design
are registered trademarks in the United States
of America and certain other countries.*

Taylor Company
750 N. Blackhawk Blvd.
Rockton, IL 61072

Section 1

To the Installer

The following are general installation instructions. For complete installation details, please see the checkout card.

Installer Safety



In all areas of the world, equipment should be installed in accordance with existing local codes. Please contact your local authorities if you have any questions.

Care should be taken to ensure that all basic safety practices are followed during the installation and servicing activities related to the installation and service of Taylor equipment.

- Only authorized Taylor service personnel should perform installation and repairs on the equipment.
- Authorized service personnel should consult OSHA Standard 29CFR1910.147 or the applicable code of the local area for the industry standards on lockout/tagout procedures before beginning any installation or repairs.
- Authorized service personnel must ensure that the proper PPE is available and worn when required during installation and service.
- Authorized service personnel must remove all metal jewelry, rings, and watches before working on electrical equipment.



The main power supply(s) to the freezer must be disconnected prior to performing any repairs. Failure to follow this instruction may result in personal injury or death from electrical shock or hazardous moving parts as well as poor performance or damage to the equipment.

Note: All repairs must be performed by an authorized Taylor Service Technician.



This unit has many sharp edges that can cause severe injuries.

Site Preparation

Review the area where the unit will be installed before uncrating the unit. Make sure all possible hazards to the user or the equipment have been addressed.

For Indoor Use Only: This unit is designed to operate indoors, under normal ambient temperatures of 70°-75°F (21°-24°C). The freezer has successfully performed in high ambient temperatures of 104° (40°C) at reduced capacities.



This unit must **NOT** be installed in an area where a water jet or hose can be used. **NEVER** use a water jet or hose to rinse or clean the unit. Failure to follow this instruction may result in electrocution.



This unit must be installed on a level surface to avoid the hazard of tipping. Extreme care should be taken in moving this equipment for any reason. Two or more persons are required to safely move this unit. Failure to comply may result in personal injury or equipment damage.

Uncrate the unit and inspect it for damage. Report any damage to your Taylor Distributor.

This piece of equipment is made in the USA and has USA sizes of hardware. All metric conversions are approximate and vary in size.

Air Cooled Units

DO NOT obstruct air intake and discharge openings:

Air cooled units require a minimum of 6" (152 mm) of clearance on both sides and 4" (102 mm) of clearance on the bottom of the freezer. To prevent warm exhaust from recirculating, place the rear of the unit against the wall. This will allow adequate air flow across the condenser.

Electrical Connections

In the United States, this equipment is intended to be installed in accordance with the National Electrical Code (NEC), ANSI/NFPA 70-1987. The purpose of the NEC code is the practical safeguarding of persons and property from hazards arising from the use of electricity. This code contains provisions considered necessary for safety. In all other areas of the world, equipment should be installed in accordance with the existing local codes. Please contact your local authorities.



FOLLOW YOUR LOCAL ELECTRICAL CODES!

Each unit requires one power supply for each data label on the unit. Check the data label(s) on the freezer for branch circuit overcurrent protection or fuse, circuit ampacity, and other electrical specifications. Refer to the wiring diagram provided inside of the electrical box for proper power connections.



CAUTION: THIS EQUIPMENT MUST BE PROPERLY GROUNDED! FAILURE TO DO SO CAN RESULT IN SEVERE PERSONAL INJURY FROM ELECTRICAL SHOCK!



This unit is provided with an equipotential grounding lug that is to be properly attached to the rear of the frame by the authorized installer. The installation location is marked by the equipotential bonding symbol (5021 of IEC 60417-1) on both the removable panel and the equipment's frame.



- Stationary appliances which are not equipped with a power cord and a plug or another device to disconnect the appliance from the power source must have an all-pole disconnecting device with a contact gap of at least 3 mm installed in the external installation.
- Appliances that are permanently connected to fixed wiring and for which leakage currents may exceed 10 mA, particularly when disconnected, not used for long periods, or during initial installation, shall have protective devices such as a GFI to protect against the leakage of current, installed by authorized personnel to the local codes.
- Supply cords used with this unit shall be oil-resistant, sheathed flexible cable, not lighter than ordinary polychloroprene or other equivalent synthetic elastomer-sheathed cord (Code designation 60245 IEC 57) installed with the proper cord anchorage to relieve conductors from strain, including twisting, at the terminals and protect the insulation of the conductors from abrasion.

Electrical Hook-up Installation

For 60 Cycle, 1 PH, Supplied With Cord and Plug

This equipment is supplied with a 3-wire cord and grounding type plug for connection to a single phase, 60 cycle, branch circuit supply. This unit must be plugged into a properly grounded receptacle. The cord and plug provided for 115/60/1 and 208-230/60/1 is 15 amp.; therefore the wall outlet must also be 15 amp. Check the data label located on the rear of the freezer for electrical specifications.

IMPORTANT: In order to secure the compressor and to minimize vibration during shipment, two shipping bolts have been added to the base pan of the unit. Before installation, these bolts must be removed.

Permanent wiring may be used if local codes require it. Instructions for conversion to permanent wiring are as follows:



IMPORTANT: This procedure must be performed by a qualified electrician.

1. Be sure the freezer is electrically disconnected.
2. Remove the appropriate panel and locate the control box at the back of the freezer.
3. Remove the factory-installed cord and strain relief bushing.
4. Route incoming permanent wiring through 7/8" (22 mm) hole in base pan.
5. Connect two power supply leads, attach ground (earth) wire to the grounding lug inside the electrical box.
6. Be sure unit is properly grounded before applying power.



FOLLOW YOUR LOCAL ELECTRICAL CODES!

Refrigerant



In consideration of our environment, Taylor proudly uses only earth friendly HFC refrigerants. The HFC refrigerant used in this unit is R404A. This refrigerant is generally considered non-toxic and non-flammable, with an Ozone Depleting Potential (ODP) of zero (0).

However, any gas under pressure is potentially hazardous and must be handled with caution.

NEVER fill any refrigerant cylinder completely with liquid. Filling the cylinder to approximately 80% will allow for normal expansion.



Refrigerant liquid sprayed onto the skin may cause serious damage to tissue. Keep eyes and skin protected. If refrigerant burns should occur, flush immediately with cold water. If burns are severe, apply ice packs and contact a physician immediately.



Taylor reminds technicians to be cautious of government laws regarding refrigerant recovery, recycling, and reclaiming systems. If you have any questions regarding these laws, please contact the factory Service Department.



WARNING: R404A refrigerant used in conjunction with polyolester oils is extremely moisture absorbent. When opening a refrigeration system, the maximum time the system is open must not exceed 15 minutes. Cap all open tubing to prevent humid air or water from being absorbed by the oil.

Section 2

To the Operator

Your freezer has been carefully engineered and manufactured to give you dependable operation. If the Taylor Model 142 is properly operated and cared for, it will produce a consistent, quality product. Like all mechanical products, this machine will require cleaning and maintenance. A minimum amount of care is necessary if the operating procedures outlined in this manual are followed closely.

This Operator's Manual should be read before operating or performing any maintenance on your equipment.

Your Taylor freezer will NOT eventually compensate and correct for any errors during the set-up or filling operations. Thus, the initial assembly and priming procedures are of extreme importance. It is important that the personnel responsible for the equipment's operation study this manual in order to be properly trained.

In the event you should require technical assistance, please contact your local authorized Taylor Distributor.

Note: Warranty is valid only if the parts are authorized Taylor parts, purchased from an authorized Taylor Distributor, and the required service work is provided by an authorized Taylor service technician. Taylor reserves the right to deny warranty claims on equipment or parts if non-approved parts or refrigerant were installed in the machine, system modifications were performed beyond factory recommendations, or it is determined that the failure was caused by neglect or abuse.

Note: Constant research results in steady improvements; therefore, information in this manual is subject to change without notice.



If the crossed out wheeled bin symbol is affixed to this product, it signifies that this product is compliant with the EU Directive as well as other similar legislation in effect after August 13, 2005. Therefore, it must be collected separately after its use is completed, and cannot be disposed as unsorted municipal waste.

The user is responsible for returning the product to the appropriate collection facility, as specified by your local code.

For additional information regarding applicable local laws, please contact the municipal facility and/or local distributor.

Compressor Warranty Disclaimer

The refrigeration compressor(s) on this machine are warranted for the term indicated on the warranty card accompanying this machine. However, due to the Montreal Protocol and the U.S. Clean Air Act Amendments of 1990, many new refrigerants are being tested and developed, thus seeking their way into the service industry. Some of these new refrigerants are being advertised as drop-in replacements for numerous applications. It should be noted that, in the event of ordinary service to this machine's refrigeration system, **only the refrigerant specified on the affixed data label should be used.** The unauthorized use of alternate refrigerants will void your compressor warranty. It will be the owner's responsibility to make this fact known to any technician he employs.

It should also be noted that Taylor does not warrant the refrigerant used in its equipment. For example, if the refrigerant is lost during the course of ordinary service to this machine, Taylor has no obligation to either supply or provide its replacement either at billable or unbillable terms. Taylor does have the obligation to recommend a suitable replacement if the original refrigerant is banned, obsoleted, or no longer available during the five year warranty of the compressor.

Taylor will continue to monitor the industry and test new alternates as they are being developed. Should a new alternate prove, through our testing, that it would be accepted as a drop-in replacement, then the above disclaimer would become null and void. To find out the current status of an alternate refrigerant as it relates to your compressor warranty, call the local Taylor Distributor or the Taylor Factory. Be prepared to provide the Model/Serial Number of the unit in question.

We, at Taylor Company, are concerned about the safety of the operator when he or she comes in contact with the freezer and its parts. Taylor has gone to extreme efforts to design and manufacture built-in safety features to protect both you and the service technician. As an example, warning labels have been attached to the freezer to further point out safety precautions to the operator.



IMPORTANT - Failure to adhere to the following safety precautions may result in severe personal injury or death. Failure to comply with these warnings may damage the machine and its components. Component damage will result in part replacement expense and service repair expense.



DO NOT operate the freezer without reading this Operator Manual. Failure to follow this instruction may result in equipment damage, poor freezer performance, health hazards, or personal injury.

Per IEC 60335-1 and its part 2 standards, “This appliance is to be used only by trained personnel. It is not intended for use by children or people with reduced physical, sensory, or mental capabilities, or lack of experience and knowledge, unless given supervision or instruction concerning the use of the appliance by a person responsible for their safety.”



This unit is provided with an equipotential grounding lug that is to be properly attached to the rear of the frame by the authorized installer. The installation location is marked by the equipotential bonding symbol (5021 of IEC 60417-1) on both the removable panel and the equipment’s frame.



DO NOT use a water jet to clean or rinse the freezer. Failure to follow these instructions may result in serious electrical shock.



- **DO NOT** operate the freezer unless it is properly grounded.
- **DO NOT** operate the freezer with larger fuses than specified on the freezer data label.
- All repairs must be performed by an authorized Taylor service technician. The main power supplies to the machine must be disconnected prior to performing any repairs.
- Cord Connected Units: Only Taylor authorized service technicians may install a plug on this unit.
- Stationary appliances which are not equipped with a power cord and a plug or another device to disconnect the appliance from the power source must have an all-pole disconnecting device with a contact gap of at least 3 mm installed in the external installation.
- Appliances that are permanently connected to fixed wiring and for which leakage currents may exceed 10 mA, particularly when disconnected, not used for long periods, or during initial installation, shall have protective devices such as a GFI to protect against the leakage of current, installed by authorized personnel to the local codes.
- Supply cords used with this unit shall be oil-resistant, sheathed flexible cable, not lighter than ordinary polychloroprene or other equivalent synthetic elastomer-sheathed cord (Code designation 60245 IEC 57) installed with the proper cord anchorage to relieve conductors from strain, including twisting, at the terminals and protect the insulation of the conductors from abrasion.

Failure to follow these instructions may result in electrocution. Contact your local authorized Taylor Distributor for service.



- **DO NOT** allow untrained personnel to operate this machine.
- **DO NOT** operate the freezer unless all service panels and access doors are restrained with screws.
- **DO NOT** remove any internal operating parts (examples: freezer door, beater, scraper blades, etc.) unless all control switches are in the OFF position.

Failure to follow these instructions may result in severe personal injury to fingers or hands from hazardous moving parts.



This unit has many sharp edges that can cause severe injuries.

- **DO NOT** put objects or fingers in the door spout. This may contaminate the product and cause severe personal injury from blade contact.
- **USE EXTREME CAUTION** when removing the beater assembly. The scraper blades are very sharp.



This freezer must be placed on a level surface. Failure to comply may result in personal injury or equipment damage.



Cleaning and sanitizing schedules are governed by your state or local regulatory agencies and must be followed accordingly. Please refer to the cleaning section of this manual for the proper procedure to clean this unit.

DO NOT obstruct air intake and discharge openings:

6" (152 mm) minimum air space on sides and rear, and 4" (102 mm) minimum on bottom. Failure to follow this instruction may cause poor freezer performance and damage to the machine.

For Indoor Use Only: This unit is designed to operate indoors, under normal ambient temperatures of 70° - 75°F (21° - 24°C). The freezer has successfully performed in high ambient temperatures of 104°F (40°C) at reduced capacities.

NOISE LEVEL: Airborne noise emission does not exceed 78 dB(A) when measured at a distance of 1.0 meter from the surface of the machine and at a height of 1.6 meters from the floor.

Section 4

Operator Parts Identification

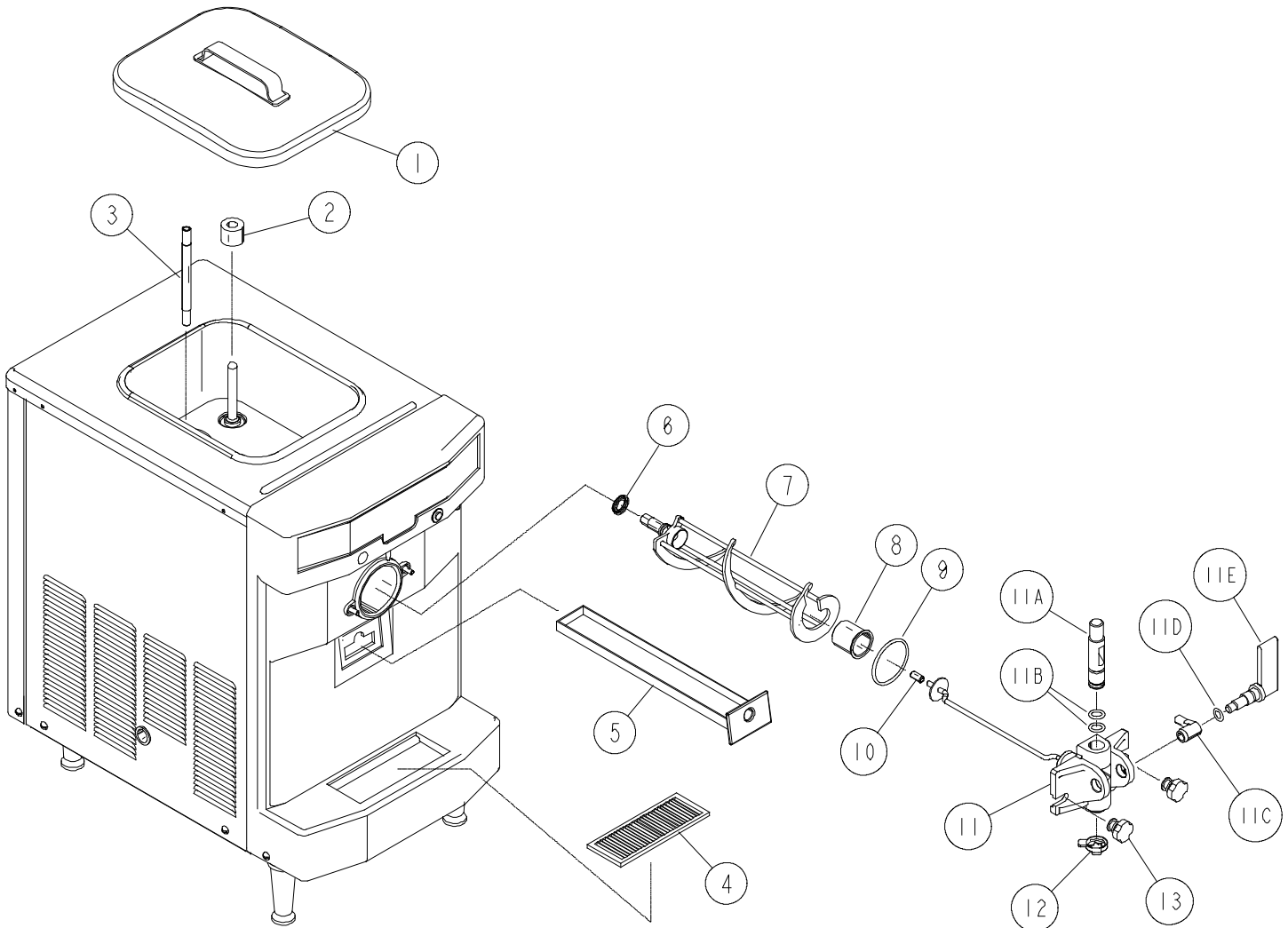

| ITEM | DESCRIPTION | PART NO. |
|------|-------------------------|----------|
| 1 | Hopper Cover | X49633 |
| 2 | Float-Mix Level | X39690 |
| 3 | Feed Tube | 035819 |
| 4 | Splash Shield | 039444 |
| 5 | Drip Pan | X43474 |
| 6 | Seal-U-Cup | 080534 |
| 7 | Beater | X24689 |
| 8 | Front Bearing | 023262 |
| 9 | O-Ring 2-3/4 OD x .139W | 019998 |

| ITEM | DESCRIPTION | PART NO. |
|------|-----------------------|------------|
| 10 | Bearing Guide | 014496 |
| 11 | Door A.-1 Spout | X38959-SER |
| 11A | Draw Valve | 024763 |
| 11B | O-Ring 7/8 OD x .103W | 014402 |
| 11C | Valve Lifter Arm | 024761 |
| 11D | O-Ring 3/4 OD x .103 | 015835 |
| 11E | Door Handle | 024762 |
| 12 | Design Cap | 014218 |
| 13 | Stud Nut | 034829 |

120430

Section 5

Important: To the Operator

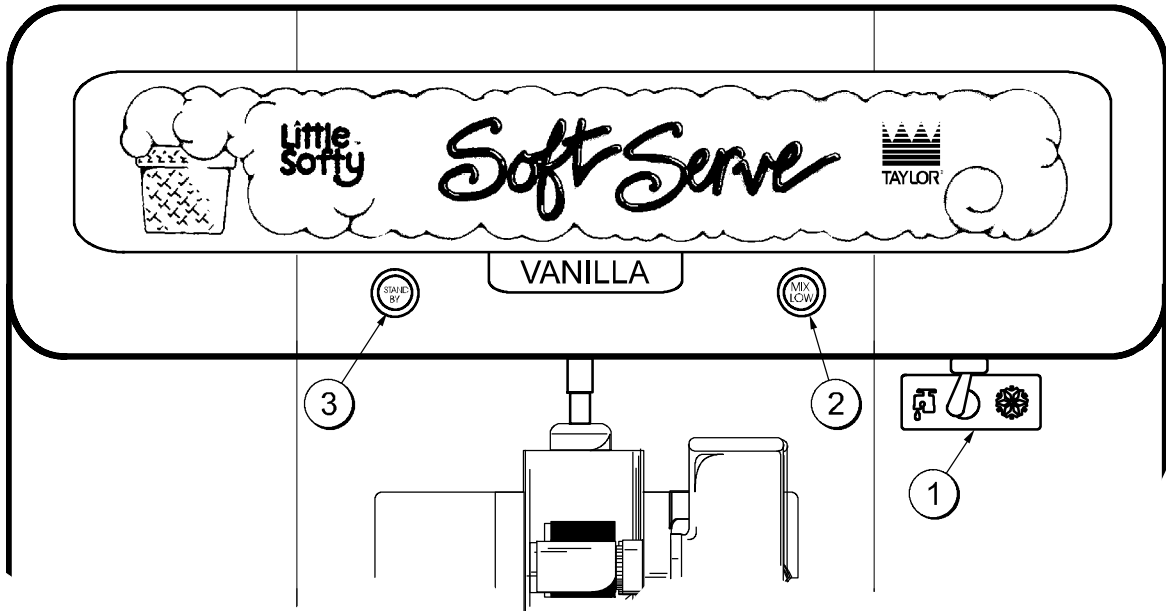





Figure 1

| ITEM | DESCRIPTION |
|------|---------------------------|
| 1 | Power Switch |
| 2 | Indicator Light - MIX LOW |
| 3 | Standby Switch |

The following chart identifies the symbol definitions used on the operator switches.

-  = ON/AUTO
-  = OFF
-  = WASH

Symbol Definitions

To better communicate in the International arena, the words on many of our operator switches and buttons have symbols to indicate their functions. Your Taylor equipment is designed with these International symbols.

Power Switch

The center position is the OFF position. The left position is WASH which activates the beater motor only. The right position is the AUTO position, which activates the beater motor and the refrigeration.

Indicator Light - MIX LOW

A mix level indicating light is located on the front of the machine. When the light is on, it indicates that the mix hopper has a low supply of mix. The hopper should be refilled immediately. Always maintain at least 2" (5.1 cm.) of mix in the hopper. If mix is not added to the hopper, the freezing cylinder may freeze. This will cause damage to the beater assembly and to the freezer door.

Standby Switch

This push button switch determines which mode of operation the freezing cylinder is operating in. If the center button of this switch is in the "OUT" position and it is not illuminated, the unit will operate in the normal product dispensing mode when the toggle switch is placed in the AUTO position.

If the center button of the standby switch is in the "IN" position and is illuminated, the machine will operate in the STANDBY mode when the toggle switch is placed in the AUTO position.

Reset Mechanism

Should an overload condition occur, the freezer will automatically shut down. To properly reset the freezer, place the toggle switch in the OFF position. Wait two or three minutes; then press the reset button located in the side panel. Place the toggle switch in the WASH position and observe the freezer's performance; return the toggle switch to the AUTO position.

Temperature Adjustments

Temperature adjustments should be performed only by an authorized Taylor Service Representative.

Feed Tube

The feed tube meters a combination of mix and air into the freezing cylinder. If mix is not added to the hopper, the freezing cylinder may freeze. This will cause damage to the beater assembly and to the freezer door. Depending upon the product being run, you may wish to contact your local authorized Taylor Distributor to make a slight adjustment in the feed tube.

When the unit is operating in the AUTO mode, the metering hole should be placed in the downward position. When the unit is placed in the STANDBY mode, the tube should be inverted.

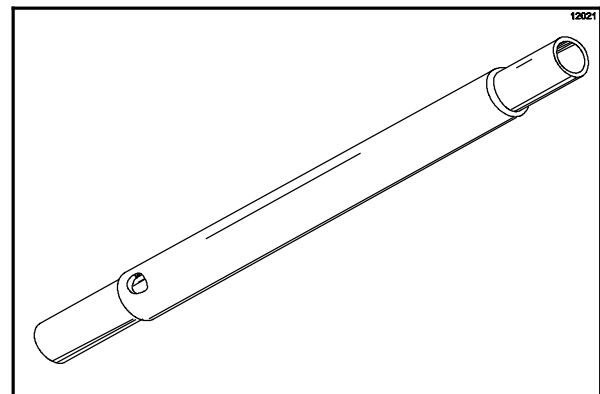

Figure 2

Section 6

Operating Procedures

The Model 142 has a 1.5 quart (1.4 liter) capacity freezing cylinder. The mix flows from the hopper to the freezing cylinder through a feed tube. The mix flow is controlled by gravity.

We begin our instructions at the point where we enter the store in the morning and find the parts disassembled and laid out to air dry from the previous night's cleaning.

These opening procedures will show you how to assemble these parts into the freezer, sanitize them and prime the freezer with fresh mix in preparation to serve your first portion.

If you are disassembling the machine for the first time or need information to get to the starting point in our instructions, turn to page 17 "Disassembly", and start there.

Assembly

Note: Use an approved food grade lubricant (example: Taylor Lube) when lubricating parts.

Step 1

Lubricate the groove on the beater drive shaft. With the opening of the cup seal facing away from the hex end, slide the seal into the groove. Apply an even coat of lubricant to the seal and the shaft. **Do not lubricate the hex end of the beater drive shaft.**

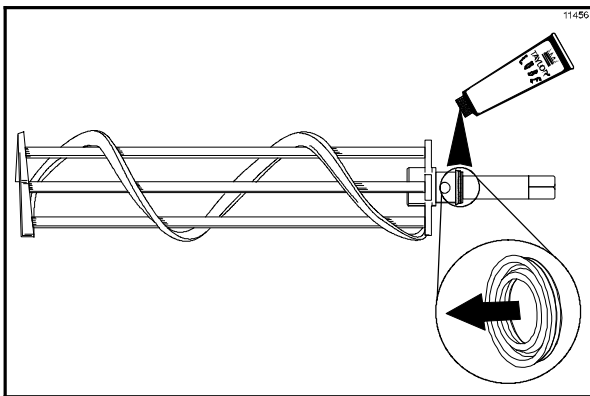

Figure 3

Step 2

Insert the beater assembly and allow the drive shaft to travel through the rear shell bearing at the back of the freezing cylinder, and engage the hex end of the drive shaft firmly into the female socket. When installed properly, the beater will not protrude beyond the front of the freezing cylinder.

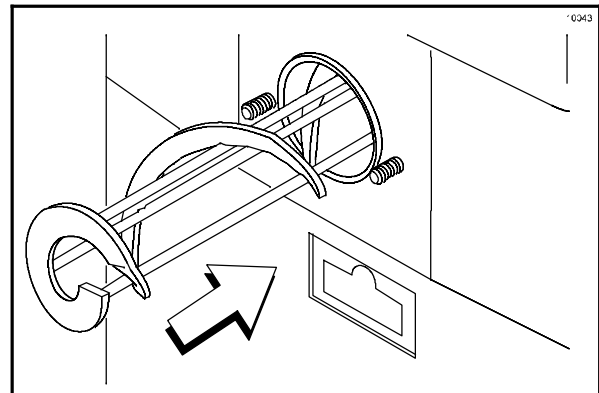

Figure 4

Step 3

Place the large o-ring into the groove on the back of the freezer door and lubricate with Taylor Lube.

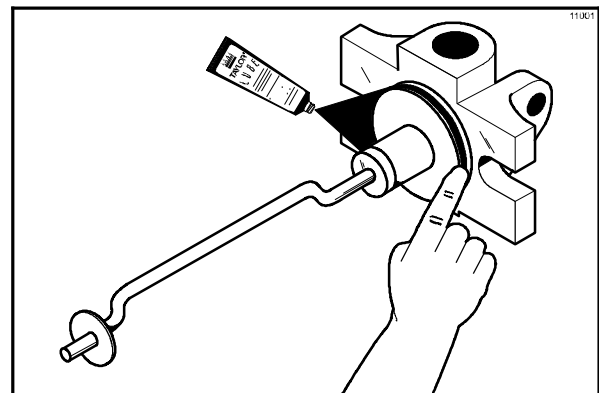

Figure 5

Step 4

Slide the front bearing over the baffle rod so the flanged edge is against the door. Place the white plastic guide bearing on the end of the baffle rod. **Do not lubricate the front bearing or guide bearing.**

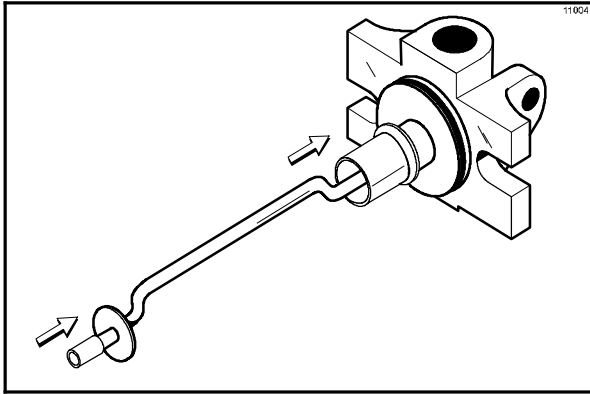

Figure 6

Step 5

Insert the handscrews into the slots in the freezer door. With both hands holding the sides of the freezer door, insert the baffle rod into the center of the beater assembly. The white guide bearing must fit securely in the hole of the drive shaft.

Step 6

Finger-tighten the handscrews, making sure they are tightened equally and that the door is snug. Do not over-tighten the handscrews.

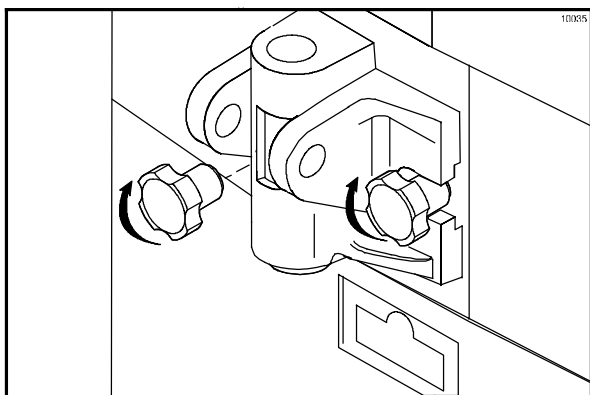

Figure 7

IMPORTANT! Handscrew and door damage can result if the handscrews are over-tightened or if one handscrew is tightened more than the other.

Step 7

Install the draw valve. Slide the two o-rings into the grooves on the draw valve and lubricate with Taylor Lube.

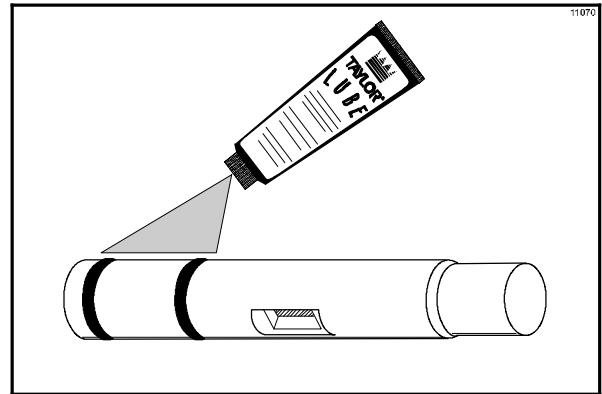

Figure 8

Lubricate the inside of the door spout from the **bottom**. Insert the draw valve into the freezer door from the **bottom**.

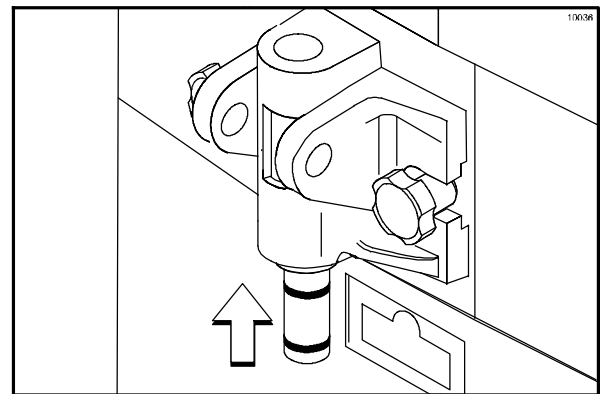

Figure 9

Note: The draw valve is installed correctly when the slotted opening in the draw valve is visible through the “window” of the freezer door.

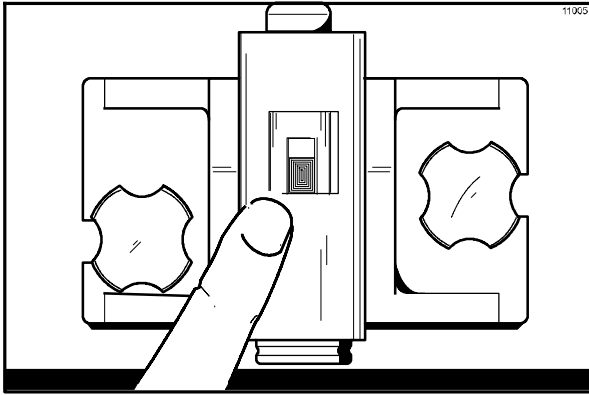

Figure 10

Step 8

Install the draw valve handle. Insert the valve lifter arm through the slotted opening in the draw valve and align the other end with the cross holes of the freezer door. **Note:** The valve lifter arm may be aligned with the left or the right cross hole. The draw valve handle will be placed through the opposite cross hole of the valve lifter arm.

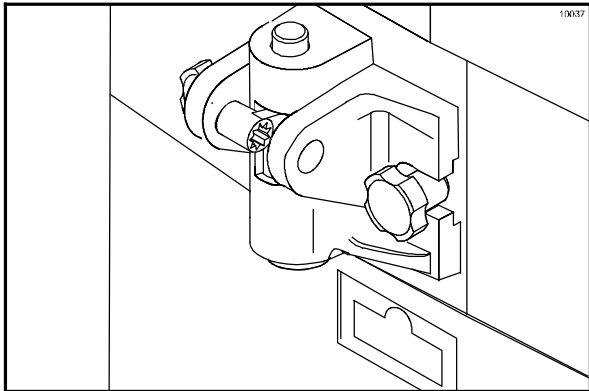

Figure 11

Slide the o-ring into the groove on the draw valve handle and lubricate with Taylor Lube.

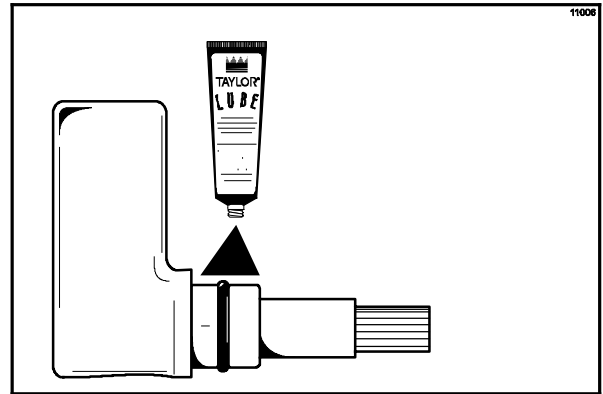

Figure 12

Insert the draw valve handle through the opposite cross hole and into the opening of the valve lifter arm.

Note: The draw valve handle can be assembled at varied vertical positions. Choose an angle which is comfortable for you, making sure the draw valve is completely raised when the draw valve handle is completely down.

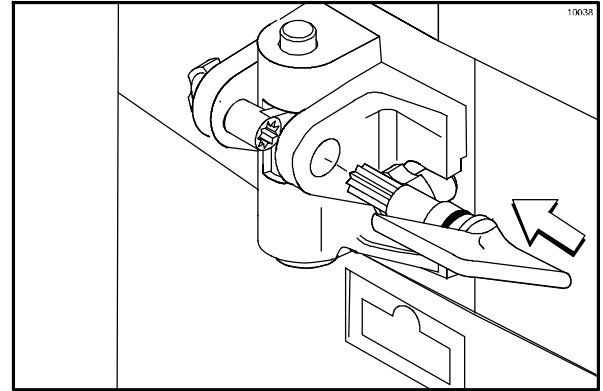

Figure 13

The illustration below shows the draw valve assembled on the left side.

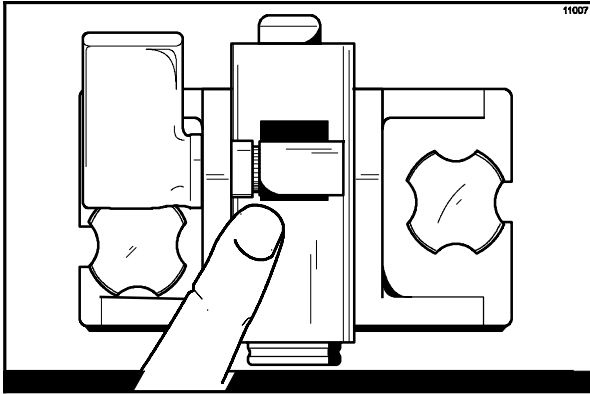

Figure 14

Step 9
Snap the design cap over the bottom of the freezer door spout.

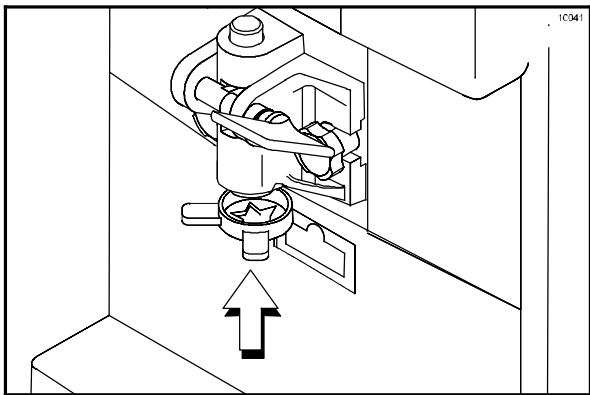

Figure 15

Step 10
Lay the feed tube and mix level float in the bottom of the mix hopper.

Sanitizing

Step 1

Prepare a pail of an approved 100 PPM sanitizing solution (examples: 2-1/2 gal. [9.5 liters] of Kay-5® or 2 gal. [7.6 liters] of Stera-Sheen®). USE WARM WATER AND FOLLOW THE MANUFACTURER'S SPECIFICATIONS.

Step 2

Pour the sanitizing solution into the hopper and allow it to flow into the freezing cylinder.

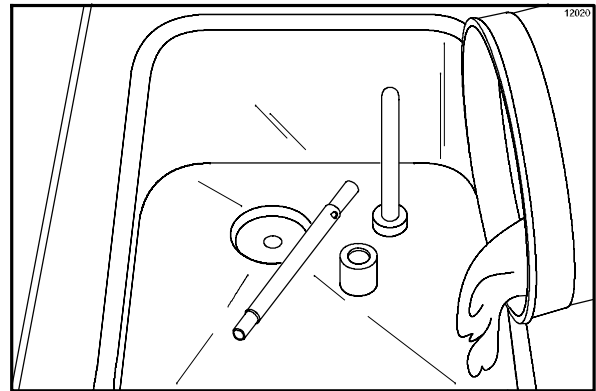

Figure 16

Step 3

While the solution is flowing into the freezing cylinder, brush-clean the mix hopper, mix level float stem, mix level float, mix inlet hole, and air tube.

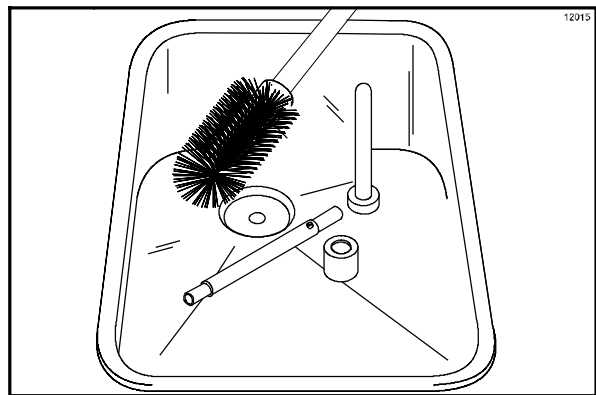

Figure 17

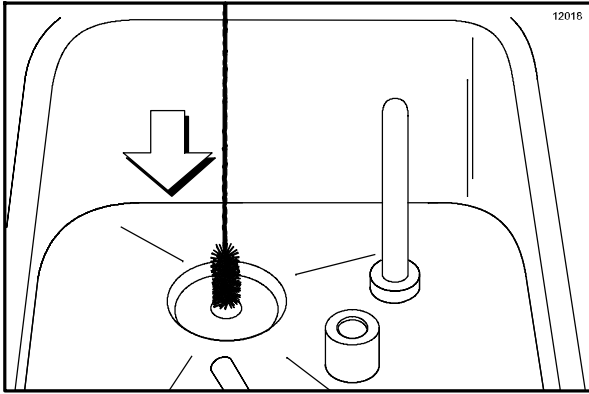

Figure 18

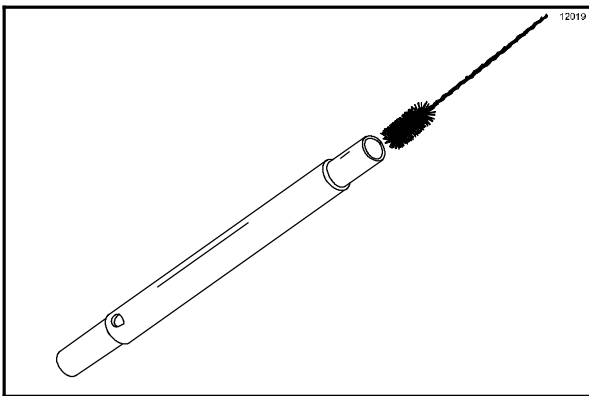

Figure 19

Step 4

Place the toggle switch in the WASH position. This will cause the sanitizing solution in the freezing cylinder to be agitated. Allow to agitate for five minutes.

Step 5

Place an empty pail beneath the door spout and open the draw valve. Draw off all the sanitizing solution. When the sanitizer stops flowing from the door spout, close the draw valve and place the toggle switch in the OFF position.

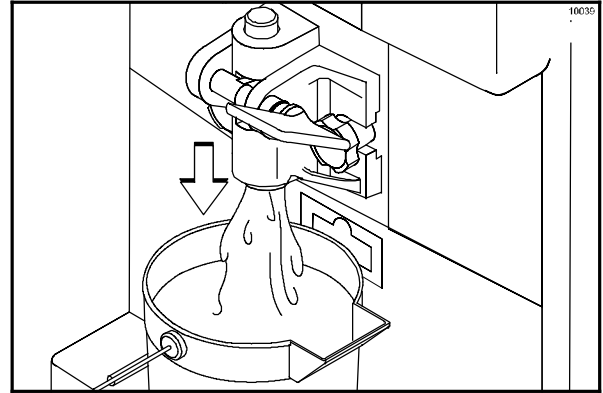

Figure 20

Step 6

Remove the feed tube from the hopper. (Be sure your hands are sanitized.)

Step 7

Place the mix level float on the mix level float stem.

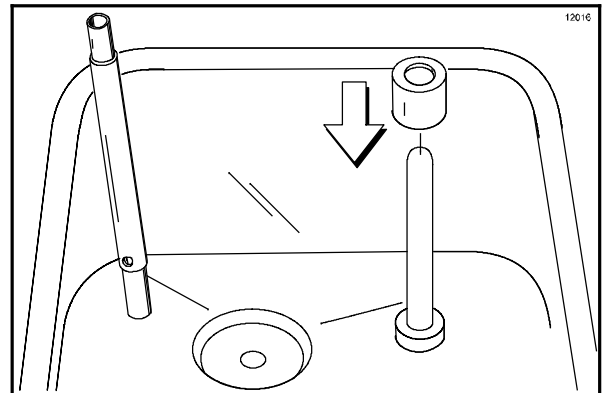

Figure 21

Priming

Prime the machine as close as possible to the time of first product draw.

Step 1

With a pail beneath the door spout, open the draw valve. Fill the mix hopper with FRESH mix and allow it to flow into the freezing cylinder. This will force out any remaining sanitizing solution. When full strength mix is flowing from the door spout, close the draw valve.

Note: Use only fresh mix when priming the freezer.

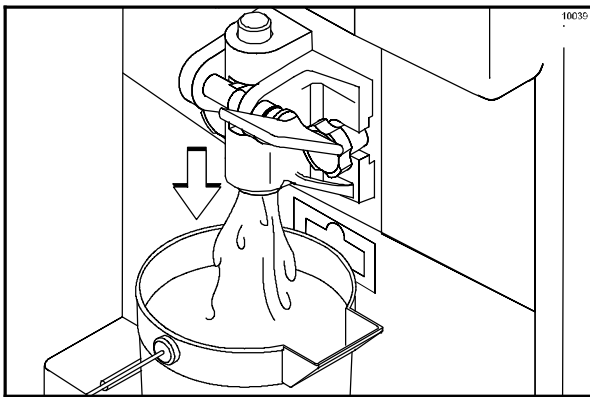

Figure 22

Step 2

When the mix has stopped bubbling down into the freezing cylinder, install the feed tube in the mix inlet hole.

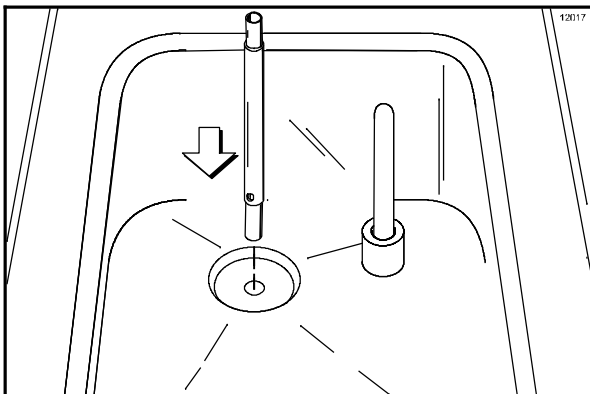

Figure 23

Step 3

Place the toggle switch in the AUTO position. When the unit cycles off, the product will be ready to serve.

Step 4

Place the mix hopper cover in position.

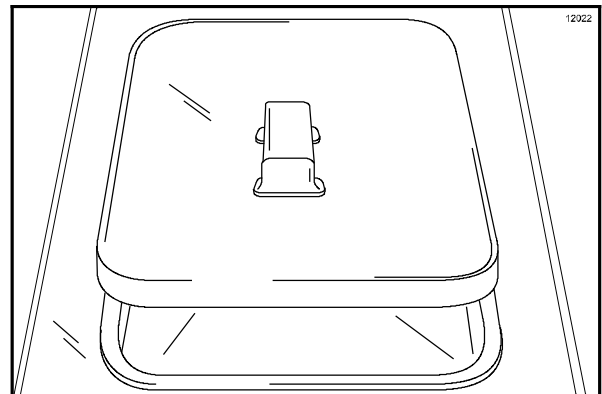

Figure 24

Step 5

Install the splash shield under the freezer door.

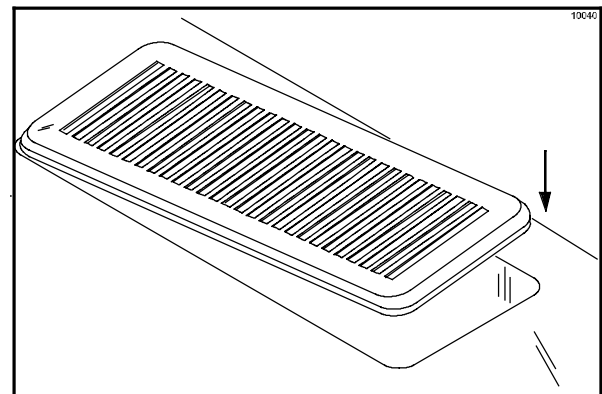

Figure 25

Step 6

Slide the rear drip pan into the hole in the front panel.

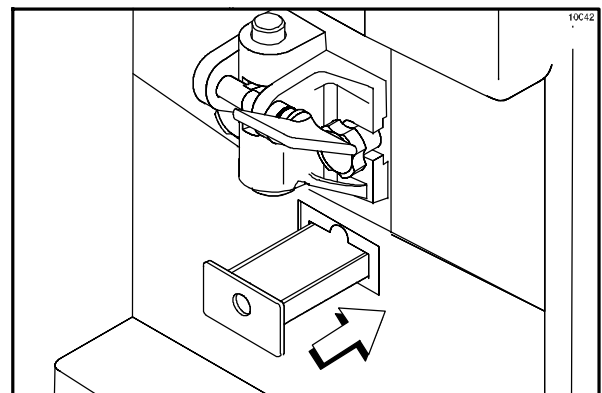

Figure 26

Standby

This unit is equipped with a STANDBY feature. If product is not dispensed for long periods of time (i.e.; early morning hours), the STANDBY feature will maintain the hopper and freezing cylinder product at safe temperatures, and prevent product breakdown.

To use the standby feature, perform the following steps:

Step 1

Verify that the hopper is adequately filled with mix, and invert the feed tube.

Step 2

Place the power switch in the AUTO position, and press the STANDBY button. The button will light, indicating that the unit is operating as a refrigerator for product in the hopper and freezing cylinder.

Step 3

To remove the unit from the STANDBY mode, place the power switch in the AUTO position, and press the standby button. The light will extinguish, indicating that the unit has resumed the normal operating mode.

Step 4

When the unit cycles off, remove the hopper cover, and place the feed tube in its original position.

Step 5

Replace the hopper cover.



IMPORTANT: The STANDBY mode must *not* be used in lieu of daily disassembly, cleaning, and sanitizing.

Closing Procedure

To disassemble the freezer, the following items will be needed:

- Two cleaning pails
- Sanitized stainless steel rerun can with lid
- Necessary brushes (provided with freezer)
- Cleaner
- Single service towels

Draining Product From the Freezing Cylinder

Step 1

Place the toggle switch in the OFF position as far ahead of cleaning time as possible to allow frozen product to soften for easier cleaning.

Step 2

Lift the hopper cover, remove the feed tube and the mix level float. Take these parts to the sink for cleaning.

Step 3

If local health codes permit the use of rerun, place a sanitized, NSF approved stainless steel rerun container beneath the door spout. Place the toggle switch in the WASH position and open the draw valve. When all the product stops flowing from the door spout, close the draw valve. Place the toggle switch in the OFF position. Place a sanitized lid on the rerun container and place it in the walk-in cooler.

(**Note:** For additional information regarding the proper use of rerun, see item 5 on page 19.)

Note: If local health codes **DO NOT** permit the use of rerun, the product must be discarded. Follow the instructions in the previous step, except drain the product into a mix pail and properly discard the mix.



ALWAYS FOLLOW LOCAL HEALTH CODES.

Rinsing

Step 1

Pour one gallon (3.8 liters) of **cool**, clean water into the mix hopper. With the brushes provided, scrub the mix hopper, mix level float stem and mix inlet hole.

Step 2

With a pail beneath the door spout, place the toggle switch in the WASH position and open the draw valve. Drain all the rinse water from the freezing cylinder. When the rinse water stops flowing from the door spout, close the draw valve and place the toggle switch in the OFF position.

Repeat this procedure until the rinse water being drawn from the freezing cylinder is **clear**.

Cleaning

Step 1

Prepare a pail of an approved 100 PPM cleaning solution (examples: 2-1/2 gal. [9.5 liters] of Kay-5® or 2 gal. [7.6 liters] of Stera-Sheen®). USE WARM WATER AND FOLLOW THE MANUFACTURER'S SPECIFICATIONS.

Step 2

Pour the cleaning solution into the mix hopper and allow it to flow into the freezing cylinder.

Step 3

While the solution is flowing into the freezing cylinder, brush clean the mix hopper, mix level float stem and mix inlet hole.

Step 4

Place the toggle switch in the WASH position. This will cause the cleaning solution in the freezing cylinder to be agitated.

Step 5

Place an empty pail beneath the door spout and open the draw valve. Draw off all the cleaning solution. When the solution stops flowing from the door spout, close the draw valve and place the toggle switch in the OFF position.

Disassembly

Step 1



Be Sure the Toggle Switch is in the "OFF" Position to Eliminate the Chance of Moving Parts.

Step 2

Remove the handscrews and freezer door. Remove the beater assembly from the freezing cylinder and take these parts to the sink for cleaning.

Step 3

Remove the splash shield from the freezer and take to the sink for cleaning.

Step 4

Remove the rear drip pan from the front panel. Take it to the sink for cleaning.

Note: If the drip pan is filled with an excessive amount of mix, this is an indication that the drive shaft o-ring of the beater assembly should be replaced or lubricated properly.

Brush Cleaning

Step 1

Prepare a sink with an approved cleaning solution (examples: Kay-5® or Stera-Sheen®). USE WARM WATER AND FOLLOW THE MANUFACTURER'S SPECIFICATIONS. (**IMPORTANT:** Follow the label directions. A STRONG solution can cause parts damage. A MILD solution will not provide adequate cleaning.) Make sure all brushes provided with the freezer are available for brush cleaning.

Step 2

Remove the o-ring from the drive shaft of the beater assembly.

Note: To remove o-rings, use a towel to grasp the o-ring. Apply pressure in an upward direction until the o-ring pops out of its groove. With the other hand, push the top of the o-ring forward, and it will roll out of the groove and can be easily removed. If there is more than one o-ring to be removed, always remove the rear o-ring first. This will allow the o-ring to slide over the forward rings without falling into the open grooves.

Step 3

From the freezer door, remove the design cap, draw valve handle, valve lifter arm, and draw valve. Remove all o-rings.

Step 4

Remove the large o-ring, the front bearing, and the guide bearing from the back of the freezer door.

Step 5

Thoroughly brush clean all disassembled parts in the cleaning solution, making sure all lubricant and mix film is removed. Take particular care to brush clean the draw valve core in the freezer door. Place all the cleaned parts on a clean, dry surface to air dry overnight.

Step 6

Return to the freezer with a small amount of cleaning solution. With the black bristle brush, brush clean the rear shell bearing at the back of the freezing cylinder.

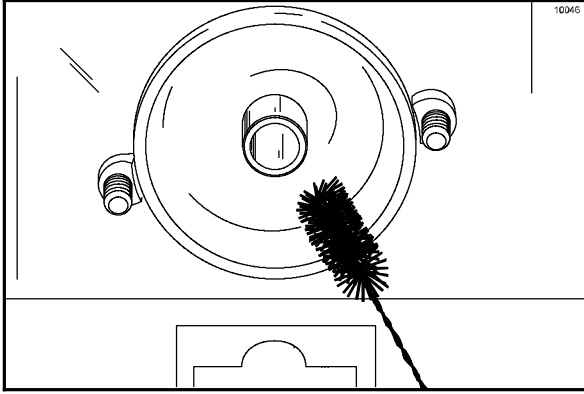

Figure 27

Step 7

Clean all exterior surfaces of the freezer.

Section 7 Important: Operator Checklist

During Cleaning and Sanitizing:

Cleaning and sanitizing schedules are governed by federal, state, or local regulatory agencies, and must be followed accordingly. If the unit has a “Standby mode”, it must not be used in lieu of proper cleaning and sanitizing procedures and frequencies set forth by the ruling health authority. The following check points should be stressed during the cleaning and sanitizing operations.



CLEANING AND SANITIZING MUST BE PERFORMED DAILY.



ALWAYS FOLLOW LOCAL HEALTH CODES.

Troubleshooting Bacterial Count:

- 1. Thoroughly clean and sanitize machine regularly, including complete disassembly and brush cleaning.
- 2. Use all brushes supplied for thorough cleaning. The brushes are specially designed to reach all mix passageways.
- 3. Use the smaller white bristle brush to clean the mix inlet hole which extends from the mix hopper down to the rear of the freezing cylinder.
- 4. Use the black bristle brush to thoroughly clean the rear shell bearing located at the rear of the freezing cylinder. Be sure to have a generous amount of cleaning solution on the brush.
- 5. IF LOCAL HEALTH CODES PERMIT THE USE OF RERUN, make sure the mix rerun is stored in a sanitized, covered stainless steel container and used the following day. DO NOT prime the machine with rerun. When using

rerun, skim off the foam and discard; then mix the rerun with fresh mix in a ratio of 50/50 during the day’s operation.

- 6. On a designated day of the week, run the mix as low as feasible and discard after closing. This will break the rerun cycle and reduce the possibility of high bacteria counts.
- 7. Properly prepare the cleaning and sanitizing solutions. Read and follow label directions carefully. Too strong of a solution may damage the parts and too weak of a solution will not do an adequate job of cleaning or sanitizing.
- 8. Temperature of mix in mix hopper and walk-in cooler should be below 40°F. (4.4°C).

Regular Maintenance Checks:

- 1. Check the rear shell bearing for signs of wear (excessive mix leakage in rear drip pan). Verify that it has been cleaned properly.
- 2. Using a screwdriver and cloth towel, keep the rear shell bearing and the female hex drive socket clean and free of lubricant and mix deposits.
- 3. Dispose of o-rings and seals if they are worn, torn, or fit too loosely. Replace these o-rings with new ones.
- 4. Follow all lubricating procedures as outlined in “Assembly”.
- 5. Check the condenser for accumulation of dirt and lint. A dirty condenser will reduce the efficiency and capacity of the machine. Condensers should be cleaned **monthly** with a soft brush.
Note: For machines equipped with an air filter, it will be necessary to vacuum clean the filters on a monthly schedule.



Never use screwdrivers or other metal probes to clean between the fins.

Winter Storage

If the place of business is to be closed during the winter months, it is important to protect the freezer by following certain precautions, particularly if the building is subject to freezing conditions.

Disconnect the freezer from the main power source to prevent possible electrical damage.

Your local Taylor Distributor can perform this service for you.

Wrap detachable parts of the freezer such as beater, blades, drive shaft, and freezer door, and place in a protected dry place. Rubber trim parts and gaskets can be protected by wrapping with moisture-proof paper. All parts should be thoroughly cleaned of dried mix or lubrication accumulations which attract mice and other vermin.

Section 8

Troubleshooting Guide

| PROBLEM | PROBABLE CAUSE | REMEDY | PAGE REF. |
|---|---|--|-----------|
| 1. No product being dispensed. | a. Toggle switch in OFF position. | a. Place toggle switch in the AUTO position. | 15 |
| | b. Inadequate level of mix in mix hopper. | b. Fill mix hopper with mix. | 15 |
| | c. Beater motor overloaded. | c. Place the toggle switch in the OFF position. Allow the motor to cool. Reset beater motor. Place the toggle switch in the AUTO position. | 8 |
| | d. Unit unplugged at wall receptacle. | d. Plug in power cord. | --- |
| | e. Tripped circuit breaker or blown fuse. | e. Place the circuit breaker in the ON position or replace fuse. | --- |
| | f. Freezer door was assembled incorrectly. | f. See "Operating Procedures" for proper installation. | 10 |
| | g. Product is being drawn off far in excess of freezer's capacity. | g. Stop drawing product and allow unit to recover. | --- |
| | h. Feed tube incorrectly installed. | h. Install feed tube according to instructions in this manual. | 16 |
| 2. Machine will not operate in the AUTO position. | a. Unit unplugged. | a. Plug in power cord. | --- |
| | b. Circuit breaker tripped or fuse blown. | b. Place the circuit breaker in the ON position or replace fuse. | --- |
| | c. Beater motor overloaded, causing a loss of power to the toggle switch. | c. Place the toggle switch in the OFF position. Allow the motor to cool. Reset beater motor. Place toggle switch in the AUTO position. | 8 |
| 3. Product is too stiff. | a. The temperature control is set too cold. | a. Call service technician. | --- |

| PROBLEM | PROBABLE CAUSE | REMEDY | PAGE REF. |
|--|--|--|-----------|
| 4. Product is too soft. | a. The temperature control is set too warm. | a. Call service technician. | - - - |
| | b. The feed tube is not installed. | b. Install the feed tube in mix inlet hole at bottom of the mix hopper. (The metering hole should be at the bottom of the tube.) | 15/ 16 |
| | c. Out-drawing the freezer's capacity. | c. Two 4 oz. (113.4 gram) servings in one minute. | - - - |
| 5. The freezing cylinder walls are scored. | a. Operating freezer without front bearing on freezer door. | a. Install front bearing on freezer door. | 11 |
| | b. Rear bearing unit is out of alignment. | b. Contact service technician. | - - - |
| 6. Excessive leakage in rear drip pan. | a. Worn or defective o-ring on beater drive shaft. | a. Replace every 3 months. | 23 |
| | b. Worn rear shell bearing. | b. Contact service technician. | - - - |
| | c. Incorrect lubricant. | c. Use food grade lubricant (example: Taylor Lube). | 10 |
| | d. Inadequate lubrication of beater drive shaft. | d. Lubricate properly. | 10 |
| 7. Draw valve leaking. | a. Incorrect lubricant. | a. Use food grade lubricant (example: Taylor Lube). | 11 |
| | b. Worn or defective o-rings on draw valve. | b. Replace every 3 months. | 23 |
| | c. Inadequate lubrication of draw valve. | c. Lubricate properly. | 11 |
| 8. Product not feeding into freezing cylinder. | a. Inadequate level of mix in mix hopper. | a. Fill mix hopper with mix. | 15 |
| | b. Mix inlet hole frozen up. | b. Call service technician. | - - - |
| | c. Feed tube incorrectly installed. | c. Place feed hole at the bottom. | 15 |
| 9. Unit goes out on overload excessively. | a. Too many appliances plugged into the circuit. | a. A separate 15 amp. circuit is needed for the freezer to operate properly. | - - - |
| | b. Extension cord placed between power cord and wall receptacle. | b. If extension cord is used, it must match the power cord in size of wire ampacity. | - - - |

Section 9

Parts Replacement Schedule

| PART DESCRIPTION | EVERY 3 MONTHS | EVERY 6 MONTHS | ANNUALLY | QUANTITIES TO BE REPLACED |
|------------------------------|----------------|--------------------------------|----------|---------------------------|
| Beater Drive Shaft Cup Seal | X | | | 1 |
| Freezer Door O-Ring | X | | | 1 |
| Freezer Door Front Bearing | X | | | 1 |
| Freezer Door Guide Bearing | X | | | 1 |
| Draw Valve O-Ring | X | | | 2 |
| Draw Valve Handle O-Ring | X | | | 1 |
| Black Bristle Brush, 1" x 2" | | Inspect & Replace if Necessary | Minimum | 1 |
| Double Ended Brush | | Inspect & Replace if Necessary | Minimum | 1 |
| White Bristle Brush, 3" x 7" | | Inspect & Replace if Necessary | Minimum | 1 |

Refer to Parts List on the next page when ordering the above parts.

Section 10

Parts List

| DESCRIPTION | PART NUMBER | 142 QTY. | WARR. CLASS | REMARKS |
|---------------------------------|-------------|----------|-------------|---------------------------------------|
| BEARING-FRONT | 023262 | 1 | 000 | |
| BEARING-GUIDE | 014496 | 1 | 000 | |
| BEARING-REAR SHELL *150-52-68* | 023648 | 1 | 000 | |
| +COLLAR-REAR BEARING *150-2-68* | 025564 | 1 | 000 | |
| +NUT-REAR BEARING *150-52-68* | 023647 | 1 | 000 | |
| +TAB-BEARING LOCK *150-2-68* | 025027 | 1 | 000 | |
| BEARING-UNIT REAR | 024764 | 1 | 103 | |
| +COUPLING-SERVICE | 034147 | 1 | 103 | FOR REAR BEARING UNIT - 024764 |
| BEATER A. *150-2-162-168* | X24689 | 1 | 103 | |
| +SEAL-U-CUP | 080534 | 1 | 000 | |
| BELT-HTD PITCH LENGTH 565MM | 041585 | 1 | 000 | COGGED - IDLER PULLEY TO BEARING UNIT |
| BELT-V-4L370 | 004227 | 1 | 000 | LARGE PULLEY TO BEATER MOTOR |
| BLOCK-TERMINAL 5 POLE | 024329 | 1 | 0103 | |
| BRUSH-DOUBLE ENDED-PUMP&FEED T | 013072 | 1 | 000 | |
| BRUSH-MIX PUMP BODY-3"X7"WHITE | 023316 | 1 | 000 | |
| BRUSH-REAR BRG 1IN.DX2IN.LGX14 | 013071 | 1 | 000 | |
| CAP-DESIGN-1.010"ID-6 POINT | 014218 | 1 | 000 | |
| COMPRESSOR AKA9462ZZXA-AK1 | 049302-12 | 1 | 512 | 115V 60HZ 1PH |
| +CAPACITOR-RUN 25UF/370VAC | 023739 | 1 | 103 | 115V 60HZ 1PH |
| +CAPACITOR-START 72-88UF/2 | 039557-27 | 1 | 103 | 115V 60HZ 1PH |
| +RELAY-START-COMPRESSOR | 045432-12 | 1 | 103 | 115V 60HZ 1PH |
| COMPRESSOR AKA9462ZXD-AK1 | 049302-27 | 1 | 512 | 208-230V 60HZ 1PH - S/N J6012926 & UP |
| +CAPACITOR-RUN 15UF/370V | 027087 | 1 | 103 | 208-230V 60HZ 1PH |
| +CAPACITOR-START 72-88UF/3 | 039567 | 1 | 103 | 208-230V 60HZ 1PH |
| +RELAY-START-COMPRESSOR | 048150 | 1 | 103 | 208-230V 60HZ 1PH |
| CONDENSER-AC-12LX16HX2.5T3ROW | 048935 | 1 | 103 | |
| CORD-POWER | 085093 | 1 | 103 | 115V 60HZ 1PH |
| CORD-POWER-250V-15A-95"L | 042936-27 | 1 | 103 | 208-230V 60HZ 1PH |
| COVER A.-HOPPER | X49633 | 1 | 103 | |
| DECAL-CLEAN INST.-HOPPER | 019029 | 1 | 000 | |
| DECAL-MAG-FLAVOR PADS | 039713 | 1 | 000 | |
| DECAL-MAG-FROZEN YOGURT | 039717 | 1 | 000 | |

+ Available Separately

| DESCRIPTION | PART NUMBER | 142 QTY. | WARR. CLASS | REMARKS |
|--------------------------------|-------------|----------|-------------|-------------------------------|
| DECAL-MAG-SOFT SERVE | 039714 | 1 | 000 | |
| DECAL-TROUBLESHOOTING | 038374 | 1 | 000 | |
| DIAGRAM-WIRING *142* | 049264 | 1 | 000 | |
| DOOR-1 SPOUT-4" LONG | X38959-SER | 1 | 103 | |
| +O-RING-2-3/4 OD X .139W | 019998 | 1 | 000 | |
| +ARM-VALVE LIFTER | 024761 | 1 | 103 | |
| +HANDLE-DRAW | 024762 | 1 | 103 | |
| +O-RING-3/4 OD X .103W | 015835 | 1 | 000 | |
| +VALVE-DRAW *150-2* | 024763 | 1 | 103 | |
| +O-RING-7/8 OD X .103W | 014402 | 2 | 000 | |
| DRYER-FILTER 1/4 X 1/4 SOLDER | 048878 | 2 | 000 | |
| DVD-OPS TRAIN VIDEO*TAYLOR | 037665-DVD | 1 | 000 | |
| FLOAT A.-MIX LEVEL *142* | X39690 | 1 | 103 | |
| GUIDE A.-DRIP PAN *142* | X43491 | 1 | 103 | |
| HARNESS-WIRE-UPPER-HI VOLT | 043581 | 1 | 103 | INCLUDES 039534 TOGGLE SWITCH |
| HARNESS-WIRE-142-LOWER-STANDBY | 049005 | 1 | 103 | |
| KIT A.-TUNE UP*150-152* | X25802 | 1 | 000 | |
| BEARING-FRONT | 023262 | 1 | 000 | |
| BEARING-GUIDE | 014496 | 1 | 000 | |
| CAP-DESIGN-1.010"ID-6 POINT | 014218 | 1 | 000 | |
| SEAL-U-CUP | 080534 | 1 | 000 | |
| O-RING-2-3/4 OD X .139W | 019998 | 1 | 000 | |
| O-RING-3/4 OD X .103W | 015835 | 1 | 000 | |
| O-RING-7/8 OD X .103W | 014402 | 2 | 000 | |
| TOOL- O-RING REMOVAL | 048260-WHT | 1 | 000 | |
| LABEL-DOOR-MOVE PART | 032749 | 1 | 000 | |
| LABEL-SW-WASH/OFF/AUTO-SYMBOL | 014502 | 1 | 000 | |
| LABEL-WARN-COVER | 051433 | 4 | 000 | |
| LEG-4"-3/8-16 STUD-PLASTIC | 024755 | 4 | 103 | |
| LIGHT-MIX LOW-AMBER ROUND-24V | 039708 | 1 | 103 | MIX LOW |
| LUBRICANT-TAYLOR 4 OZ. | 047518 | 1 | 000 | |
| MAN-OPER 142 | 039709-M | 1 | 000 | |
| MOTOR-1/2HP 60HZ 115V 172 | 039563-12 | 1 | 212 | 115V 60HZ 1PH |

+ Available Separately

| DESCRIPTION | PART NUMBER | 142 QTY. | WARR. CLASS | REMARKS |
|---------------------------------|-------------|----------|-------------|--------------------------------|
| MOTOR-1/2HP 60HZ 230V 172 | 039563-27 | 1 | 212 | 208-230V 60HZ 1PH |
| MOTOR-FAN 50 WATT W/GROUND | 029770-12 | 1 | 103 | 115V 60HZ 1PH |
| +FAN-5 BLADE 12" PUSH 22DEG CCW | 049009 | 1 | 103 | |
| MOTOR-FAN 50 WATT W/GROUND | 029770-27 | 1 | 103 | 208-230V 60HZ 1PH |
| +FAN-5 BLADE 12" PUSH 22DEG CCW | 049009 | 1 | 103 | |
| NUT-STUD *150-152-162-168* | 034829 | 2 | 103 | HANDSCREW |
| PAN A.-WHITE FRONT DRIP*142* | X43474 | 1 | 103 | |
| PANEL-FRONT-PLASTIC | 042933 | 1 | 103 | |
| PANEL-REAR *142*STANDBY | 049001 | 1 | 103 | |
| PANEL-SIDE *142* RIGHT | 048879 | 1 | 103 | |
| PANEL-SIDE *142*LEFT | 048999 | 1 | 103 | |
| PCB A.-STANDBY CONTROL-HOPPER | X44803SER1 | 1 | 212 | 115V 60HZ 1PH |
| PCB A.-STANDBY CONTROL-HOPPER | X44803SER2 | 1 | 212 | 208-230V 60HZ 1PH |
| PLATE A.-MOUNTING DECAL *142* | X39629 | 1 | 103 | DEC PLATE |
| PROBE-THERMISTOR-BARREL-2% TOL | 038061-BLK | 1 | 103 | BARREL |
| PROBE-THERMISTOR-HOPPER-2% TOL | 039470-BLK | 1 | 103 | HOPPER |
| PULLEY-10"OD W/TIMING GEAR*142 | 046194 | 1 | 103 | INCLUDES IDLER PULLEY AND BOLT |
| +BOLT-IDLER-1/2 X 20 | 039620 | 1 | 103 | AVAILABLE FOR SERVICE |
| +NUT-SHAFT JACK *142* | 039616 | 1 | 103 | |
| +WASHER-PULLEY IDLER *142* | 039615 | 1 | 103 | |
| PULLEY-AK17X 5/8 | 031076 | 1 | 103 | BEATER MOTOR |
| PULLEY-HTD 72 TOOTH 5MM PITCH | 041095 | 1 | 103 | BEARING UNIT |
| RELAY-3 POLE-25 AMP | 067460-12 | 1 | 103 | 115V 60HZ 1PH |
| RELAY-3 POLE-25 AMP | 067460-27 | 1 | 103 | 208-230V 60HZ 1PH |
| SANITIZER-STERA SHEEN -GREEN | 055492 | 1 | 000 | |
| SANITIZER KAY-5 125 PACKETS | 041082 | 1 | 000 | |
| SENSOR A.-MIX LEVEL | X39688 | 1 | 103 | |
| SHELL A.-INSULATED *142*HOOD | X49175-SER | 1 | 512 | |
| STUD-NOSE CONE *142* | 042168 | 2 | 103 | |
| SHIELD-SPLASH-PLASTIC | 039444 | 1 | 103 | |
| SHROUD-FAN *142* | 048877 | 1 | 103 | |
| SWITCH A.-DRAW *142* | X43577-SER | 1 | 103 | |
| ACTUATOR-SWITCH-PLASTIC | 035609 | 1 | | |

+ Available Separately

| DESCRIPTION | PART NUMBER | 142 QTY. | WARR. CLASS | REMARKS |
|--------------------------------|-------------|----------|-------------|---------------------------------|
| BEARING-SWITCH | 029244 | 2 | 000 | |
| BRACKET-DRAW SWITCH | 041063 | 1 | 103 | |
| E-RING-1/4 IN-ZD | 034962 | 1 | 000 | |
| NUT-PUSH ON-1/2DIA. SHAFT | 039735 | 2 | 000 | |
| ROD-SWITCH-SQUARE *142* | 039617 | 1 | 103 | |
| SCREW-4-40X5/8 SLTD ROUND | 027219 | 2 | 000 | |
| SPRING-COMP.720X.063X2.00 | 023664 | 1 | 103 | |
| SWITCH-ACTUATOR | 035609 | 1 | 103 | |
| SWITCH-LEVER-SPDT-15A-125-250V | 027214 | 1 | 103 | |
| SWITCH-PRESSURE 440 PSI-SOLDER | 048230 | 1 | 103 | |
| SWITCH-STAND BY SPST-LIGHTED | 043279 | 1 | 103 | |
| +BULB-LIGHT 14V 142 | 043279-1 | 1 | 000 | |
| SWITCH-TOGGLE | 039534 | 1 | 103 | POWER SWITCH (SEE HARNESS-WIRE) |
| TIMER-DELAY ON MAKE 2 SEC | 030667-12 | 1 | 103 | 115V 60HZ 1PH |
| TUBE-CAPILLARY .049 X 7FT | 049172 | 1 | 103 | |
| TUBE-FEED-150-DANFOSS-.166HOLE | 035819 | 1 | 103 | |
| VALVE-ACCESS 1/4FL X 1/4SOLDER | 044404 | 1 | 103 | SUCTION LINE |
| VALVE-ACCESS 1/4FL X 3/8SDR-90 | 044455 | 1 | 103 | MAIN COMPRESSOR |
| VALVE-ACCESS-1/4 MFLX1/4 S-90 | 047016 | 1 | 103 | COMPRESSOR HIGH SIDE |
| VALVE-EPR 1/4S | 022665 | 1 | 103 | SUCTION LINE |
| VALVE-EXP-THERMO-1/4S X 1/4FPT | 051578 | 1 | 103 | (REPLACES 018217-1) 119 |
| +BOOT-EXPANSION VALVE | 027137 | 1 | 000 | |
| VALVE-SOLENOID 1/2ORF X 1/2ODF | 043681-12 | 1 | 103 | 115V 60HZ 1PH - SUCTION LINE |
| VALVE-SOLENOID 1/2ORF X 1/2ODF | 043681-27 | 1 | 103 | 208-230V 60HZ 1PH |
| VALVE-SOLENOID 7/64ORF X 1/4S | 043449-12 | 2 | 103 | 115V 60HZ 1PH - LIQUID LINE |
| VALVE-SOLENOID 7/64ORF X 1/4S | 043449-27 | 2 | 102 | 208-230V 60HZ 1PH - LIQUID LINE |

+ Available Separately

| DESCRIPTION | PART NUMBER | 142 QTY. | WARR. CLASS | REMARKS |
|--------------------------------|-------------|----------|-------------|------------------------------|
| 50 Hz | | | | |
| BELT-V-4L380 | 007098 | 1 | 000 | |
| BELT-HTD PITCH LENGTH 565MM | 041585 | 1 | 000 | |
| COMPRESSOR - TECUMSEH | 049302-40 | 1 | 512 | J6012926/UP |
| +CAPACITOR-RUN | 027087 | 1 | 212 | |
| +CAPACITOR-START | 039567 | 1 | 212 | |
| +RELAY-START-COMPRESSOR | 041064 | 2 | 212 | |
| CONTROL-STANDBY-HOPPER-ROHS | X65831-SER | 1 | 212 | 50 HZ - ROHS |
| CORD A.-POWER *142* | X66720-40 | 1 | 103 | |
| DIAGRAM-WIRING *142* | 049264-40 | 1 | 000 | |
| MOTOR-FAN 50 WATT W/GROUNDWIRE | 029770-27 | 1 | 103 | |
| MOTOR-BEATER | 039563-34 | 1 | 212 | |
| SWITCH-CENTRIFUGAL-MOTOR START | 039563-001 | 1 | 212 | 50 Hz Only |
| PANEL-SIDE *142* LEFT 50HZ | 049003 | 1 | 103 | |
| PCB A.-STANDBY CONTROL-HOPPER | X44803SER2 | 1 | 212 | 50 HZ - STANDARD |
| PULLEY-HTD 72 TOOTH 5MM PITC | 041095 | 1 | 103 | |
| PULLEY-AK20X5/8 | 041162 | 1 | 103 | |
| PULLEY-10"OD W/TIMING GEAR*1 | 046194 | 1 | 103 | |
| RELAY-3 POLE-25 AMP | 067460-27 | 1 | 103 | |
| VALVE-SOLENOID 1/2ORF X 1 | 043681-27 | 1 | 103 | LINE A.-SUCTION *142* |
| VALVE-SOLENOID 7/64ORF X | 043449-27 | 2 | 103 | LINE A.-LIQUID *142*SOLENOID |

+ Available Separately

| DESCRIPTION | PART NUMBER | 142 QTY. | WARR. CLASS | REMARKS |
|--|-------------|----------|-------------|---------|
| 014212H879 - CANADA - 115V 60HZ 1PH | | | | |
| MAN-OPER-COND 142 ROMANCE | 039709RM | 1 | 000 | |
| CARD-CHECKOUT FREEZER FRE | 033941-F | 1 | 000 | |
| LABEL-ATTN SVC ENG-FRENCH | 015068-FG | 1 | 000 | |
| LABEL-CAUTION-GRD-FRENCH/ | 032164-FG | 1 | 000 | |
| LABEL-DOOR-MOVE PART-FREN | 032749-FG | 1 | 000 | |
| LABEL-WARN-COVER-FRENCH | 051433-F | 3 | 000 | |
| FRANCE | | | | |
| CARD-CHECKOUT FREEZER FRE | 033941-F | 1 | | |
| DECAL-INST-CLN HPR-FRENCH | 019029-F | 1 | | |
| DECAL-TROUBLESHOOT-FRENCH | 038374-F | 1 | | |
| LABEL-ATTN SVC ENG-FRENCH | 015068-FG | 1 | | |
| LABEL-CAUTION-GRD-CORD-FR | 032165-F | 1 | | |
| LABEL-DOOR-MOVE PART-FREN | 032749-FG | 1 | | |
| LABEL-WARN-COVER-FRENCH | 051433-F | 4 | | |
| MAN-OPER-COND 142 ROMANCE | 039709RM | 1 | | |
| GERMANY | | | | |
| CARD-CHECKOUT FREEZER GER | 033941-G | 1 | | |
| DECAL-INST-CLN HPR-GERMAN | 019029-G | 1 | | |
| DECAL-TROUBLESHOOT-GERMAN | 038374-G | 1 | | |
| LABEL-ATTN SVC ENG-FRENCH | 015068-FG | 1 | | |
| LABEL-DOOR-MOVE PART-FREN | 032749-FG | 1 | | |
| LABEL-WARN-COVER-GERMAN | 051433-G | 4 | | |
| MAN-OPER-COND 142 ROMANCE | 039709RM | 1 | | |

+ Available Separately

N - 115V
 N - 220/240V 50HZ
 L2 - 208/230V 60HZ

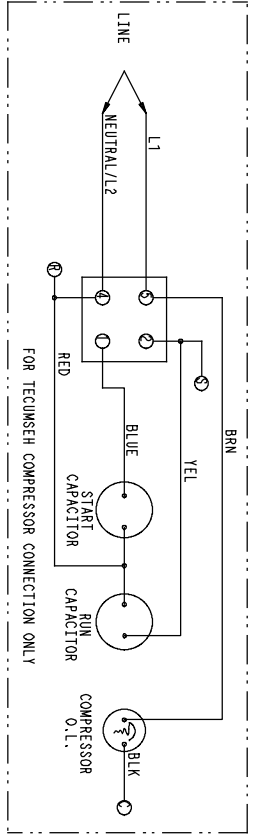
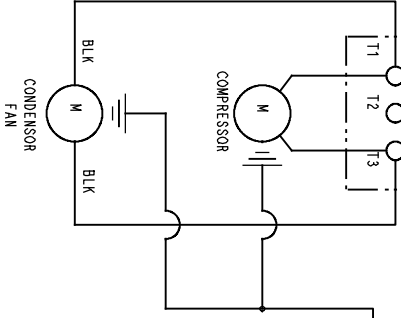
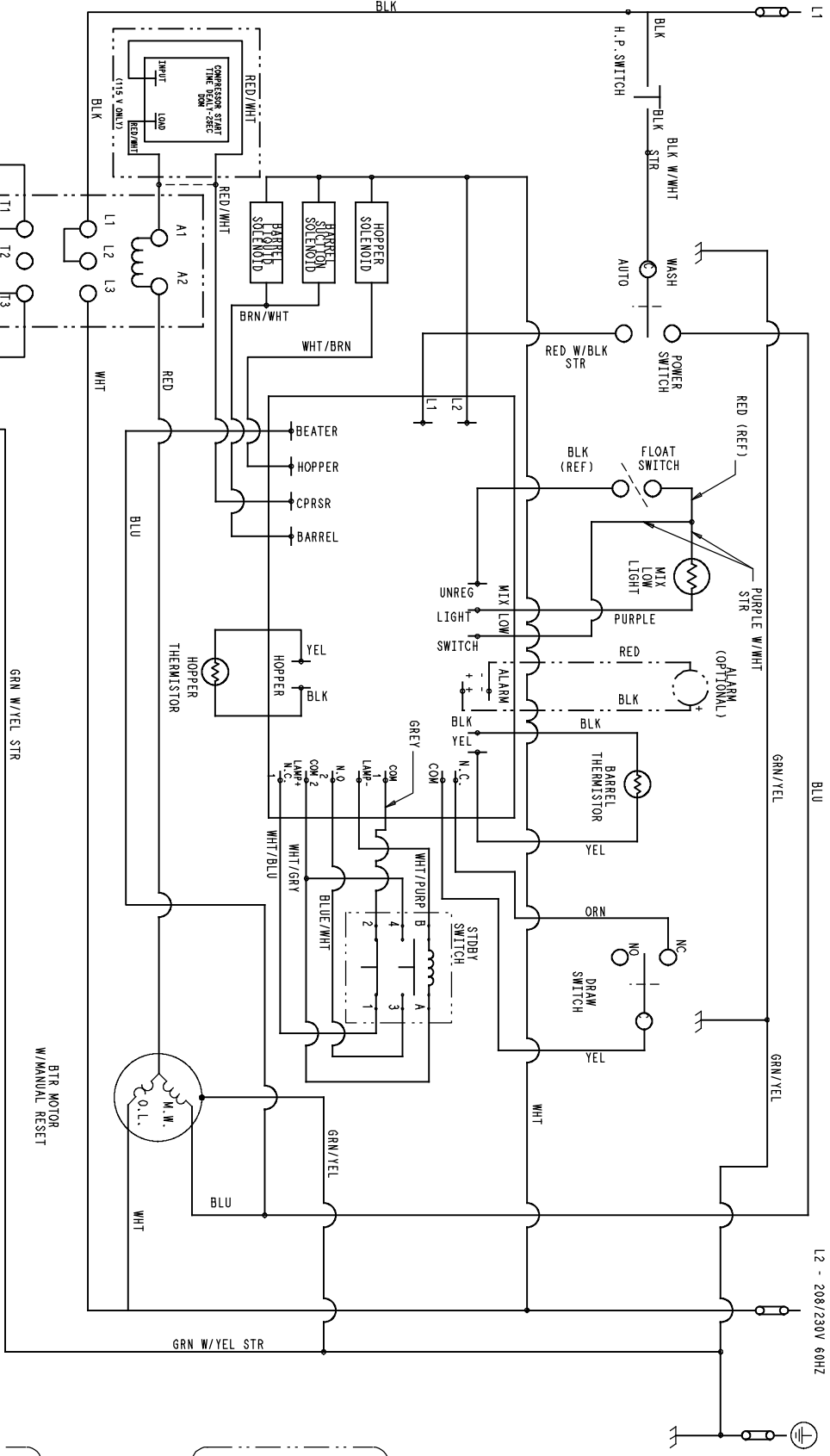

GROUND FRAME SECURELY

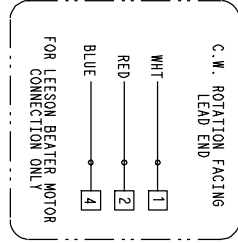
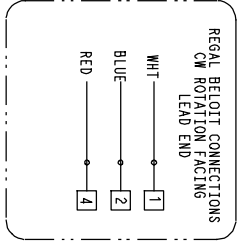

Model 142
049264
11/12/10