

QS24

Electric Grill



Shown with optional cart

Features

Cook-to-order menu items are served FAST!! With the optional platen(s) lowered, the top and bottom of the product are cooked simultaneously. Foods maintain natural juiciness, and your customers are served food hot off the grill, in less than half the time of standard grills.

Even temperatures across the entire cooking surface assures safe product integrity and fast recovery. Holding cooked food products for busy times is virtually unnecessary, reducing product waste. Multiple grills may be installed side-by-side to increase cooking surface and capacities.

Cooking Surface

Two, 12" (305 mm) wide, by 24" (610 mm) deep cooking zones with three independent heating elements per zone. Assures even temperatures and quick recovery.

Controls

Programmable microprocessor controls make menu selection simple. Includes a self-diagnostic feature for serviceability.

Temperature Control

Grill surface temperature may be set from 150 to 400°F (65 to 205°C). Optional upper platen temperature may be set from 150 to 425°F (65 to 218°C).

Indicator Lights

Lights illuminate when heaters are on.



Available with optional grooved lower cooking surface and/or grooved upper platen



QS24 Electric Grill

QS24

NOTE:
ALL DIMENSIONS ± .250

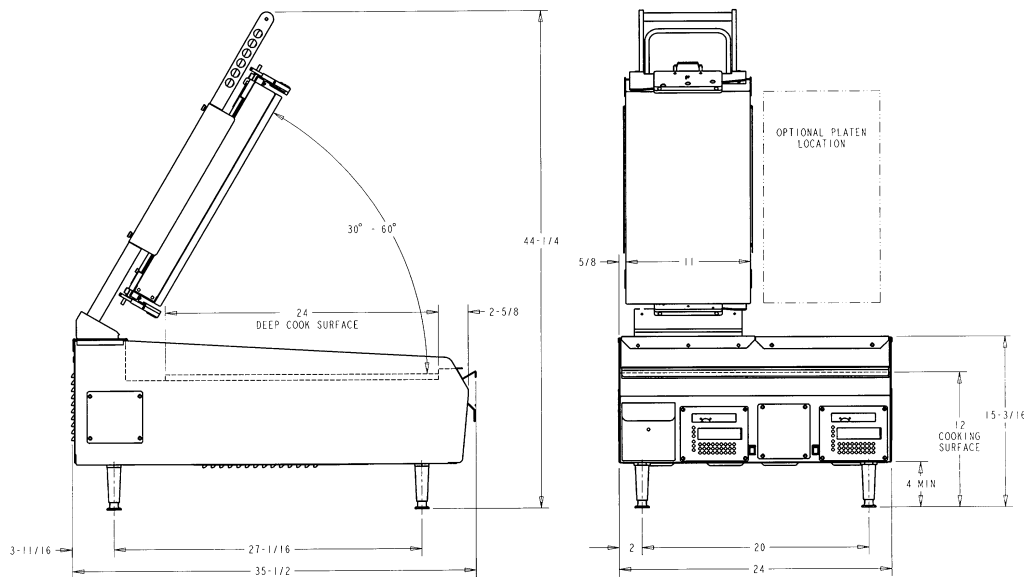

Weights shown are for the grill with one platen, or subtract for no platens.

Weights	lbs.	kgs.
Net	323	146.5
Crated	402	182.4
Volume	cu. ft.	cu. m.
Volume	21.6	0.61
Dimensions	in.	mm.
Width	24	610
Depth	35-1/2	902
Height	20	508
Counter Clearance	4	102

*Mounted on standard legs

Electrical	Total Amps	Total KW	Requires 60 Amp Cord
208/60/3 Flat (no Platen)	30	10.8	IEC309-1 & 2
208/60/3 with One Platen	42	15.0	IEC309-1 & 2
208/60/3 with Two Platens	53	19.2	IEC309-1 & 2
240/60/3 with One Platen	36	15.0	IEC309-1 & 2
240/60/3 with Two Platens	46	19.2	IEC309-1 & 2
230/400/50/3N~ with One Platen	22	15.0	IEC309-1 & 2
230/400/50/3N~ with Two Platens	28	19.2	IEC309-1 & 2

Bidding Specs

Electrical: Volt _____ Hz _____ ph _____
Neutral: Yes No

Options: _____

Specifications

Electrical

One dedicated three phase electrical connection is required. See the Electrical chart for the proper electrical requirements. Manufactured to be permanently connected. Consult your local Taylor distributor for cord & receptacle specifications as local codes allow.

Clearance

Grill clearance must be maintained at least 3" (76 mm) from all combustible materials, and 3" (76 mm) of air clearance in the rear.

Options

- Cart to make grill free-standing
- Grease Tray Drain
- Grooved Lower Cooking Surface
- Hood Stop
- Upper Platen, Flat
- Upper Platen, Grooved

Upper Platen

The upper platen has a cooking surface of 11" X 20" (279 mm X 508 mm) with three individually controlled heaters. An infinite gap adjustment will accommodate varying product thicknesses from zero to 7/8" (22 mm).

Release Material

Completely covers and protects upper platen surface, prevents product from sticking and minimizes carbon build-up. Attachment method ensures that the release material stays in place throughout the day for easy cleaning.

Cart

Adjustable legs may be set so cooking surface height is 28" (711 mm) to 33" (838 mm) in one inch increments. Net Weight: 34 lbs. (15.4 kg) Crated Weight: 37 lbs. (16.8 kg)

Continuing research results in steady improvements; therefore, these specifications are subject to change without notice.



Taylor Company,
A Division of Carrier Commercial Refrigeration, Inc.
Rockton, Illinois 61072
815-624-8333 **800-255-0626** Fax 815-624-8000
www.taylor-company.com

Printed in U.S.A.

049296-ADV 1/09