

# QS22

## Electric Grill



Shown with two platens (optional)

### Features

Cook-to-order menu items are served FAST!! With the optional platen(s) lowered, the top and bottom of the product are cooked simultaneously. With the addition of innovative Auto Lift technology, the platen raises automatically at the completion of the product cook cycle, assuring product quality and product safety every time. Foods maintain natural juiciness, and your customers are served food hot off the grill, in less than half the time of standard grills.

Even temperatures across the entire cooking surface assures safe product integrity and fast recovery. Holding cooked food products for busy times is virtually unnecessary, reducing product waste. Multiple grills may be installed side-by-side to increase cooking surface and capacities.

### Lower Cooking Surface

Two, 12" (30.5 cm) wide, by 24" (61.0 cm) deep cooking zones with three independent heating elements per zone. Assures even temperatures and quick recovery.

### Controls

Programmable microprocessor controls make menu selection simple. Includes a self-diagnostic feature for serviceability. Clear plastic door protects control from splashes or spills. Separate durable start button is provided to activate cooking cycle.

### Temperature Control

Grill surface temperature may be set from 150 to 400°F (65 to 205°C). Optional upper platen temperature may be set from 150 to 425°F (65 to 218°C).

### Indicator Lights

Lights illuminate when heaters are on.

### Utility Box

For grill scraper & release sheet wiper.



Optional grooved lower cooking surface and/or grooved upper platen



# QS22 Electric Grill

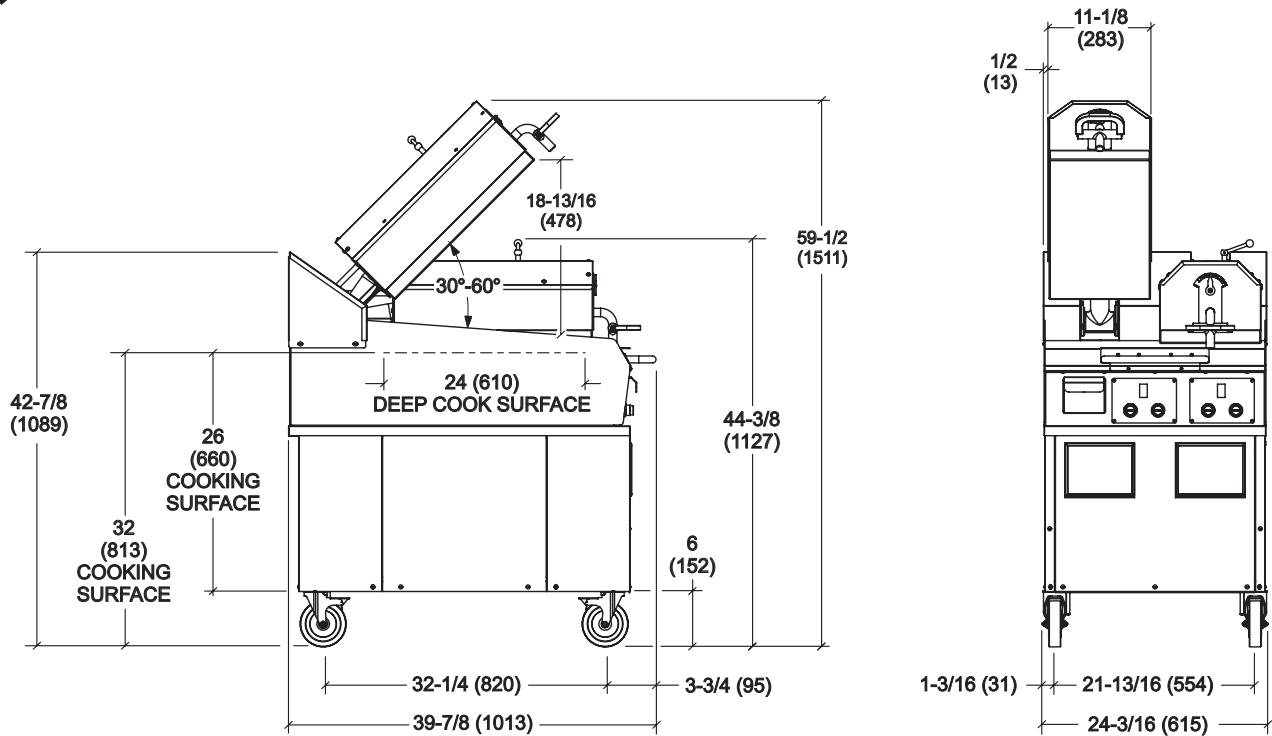

NOTE: FIGURES IN PARENTHESES INDICATE MILLIMETERS.

Weights shown are for single platen. Add 84 lbs (38.6 kgs) for second platen, or subtract for no platens.

Weights	lbs.	kgs.
Net	560	254.0
Crated	686	311.2
	cu. ft.	cu. m.
Volume	38.0	1.07

Dimensions	in.	mm.
Width	25-1/8	638
Depth	39-7/8	1013
Height	42-7/8	1089
Floor Clearance	6	152

\*Mounted on standard casters

Electrical	Total Amps	Total KW	Requires 60 Amp Cord
208/60/3 with One Platen	40	14.4	IEC309-1 & 2
208/60/3 with Two Platens	53	18	IEC309-1 & 2
230/400/50/3N~ with Two Platens	28	19.6	IEC309-1 & 2

This unit may be manufactured in other electrical characteristics. Refer to the local Taylor Distributor for availability.  
(For exact electrical information, always refer to the data label of the unit.)

### Bidding Specs

Electrical: Volt \_\_\_\_\_ Hz \_\_\_\_\_ ph \_\_\_\_\_

Neutral:  Yes  No

Options: \_\_\_\_\_

## Specifications

### Electrical

One dedicated electrical connection is required. See the Electrical chart for the proper electrical requirements.

### Clearance

Grill clearance must be maintained at least 3" (76 mm) from all combustible materials, and 3" (76 mm) of air clearance in the rear.

## Options

- Grease Tray Drain
- Grooved Lower Cooking Surface
- Upper Platen, Grooved Cooking Surface
- Upper Platen, Smooth Cooking Surface

### Upper Platen

Platen(s) raise automatically at the completion of the product cook cycle. Each upper platen has a cooking surface of 11" X 20" (279 X 508 mm) with three individually controlled heaters. An infinite gap adjustment will accommodate varying product thicknesses from zero to 1" (25.4 mm).

### Release Material

Completely covers and protects upper platen surface, prevents product from sticking and minimizes carbon build-up. Attachment method ensures that the release material stays in place throughout the day for easy cleaning.

Continuing research results in steady improvements; therefore, these specifications are subject to change without notice.



**Taylor Company,**  
A Division of Carrier Commercial Refrigeration, Inc.  
Rockton, Illinois 61072  
815-624-8333 800-255-0626 Fax 815-624-8000  
www.taylor-company.com

Printed in U.S.A.