



741

Soft Serve Freezer

Single Flavor

Features

Offer all the popular soft serve variations from low or non-fat ice creams to custards, yogurt and sorbet.

Freezing Cylinder

One, 7 quart (6.6 liter)

Mix Hopper

One, 20 quart (18.9 liter). Separate hopper refrigeration (SHR) maintains mix below 41°F (5°C) during Auto and Standby modes.

Indicator Lights

Mix Low light alerts operator to add mix.

Solid State Controls

Thermistor control precisely monitors temperature to maintain consistent quality.

Standby

During long no-use periods, the standby feature maintains safe product temperatures in the mix hopper and freezing cylinder.

Two Locking Casters

Front casters have a locking feature for operators to keep equipment in place. The lock can be released to move the equipment for cleaning.



741 Soft Serve Freezer

741

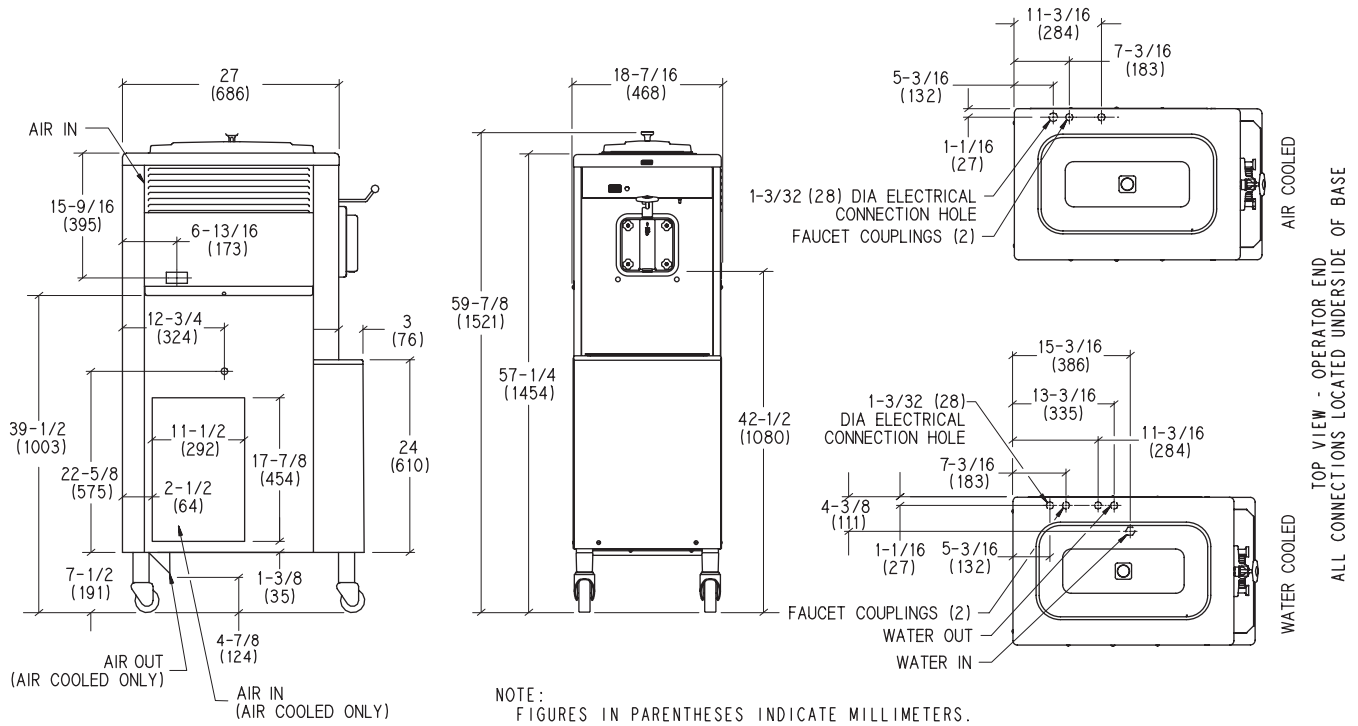

Weights	lbs.	kgs.
Net	437	198.2
Crated	496	225
Volume	cu. ft.	cu. m.
Volume	35.4	1.00
Dimensions	in.	mm.
Width	18-7/16	468
Depth	30	762
Height	59-7/8	1521
Floor Clearance	7-1/2	191

*Mounted on standard casters

Electrical	Maximum Fuse Size	Minimum Circuit Ampacity	Poles (P) Wires (W)
208-230/60/1 Air	40	31	2P 3W
208-230/60/1 Water	40	29	2P 3W
208-230/60/3 Air	25	21	3P 4W
208-230/60/3 Water	25	18	3P 4W
220-240/50/1 Air	30	25	2P 3W
380-415/50/3N~ Air	15	11	3P 4W

This unit may be manufactured in other electrical characteristics. Refer to the local Taylor Distributor for availability.

(For exact electrical information, always refer to the data label of the unit.)

Bidding Specs

Electrical: Volt _____ Hz _____ ph _____
 Neutral: Yes No Cooling: Air Water NA

Options: _____

Specifications

Electrical

One dedicated electrical connection is required. See the Electrical chart for the proper electrical requirements. Manufactured to be permanently connected. Consult your local Taylor distributor for cord & receptacle specifications as local codes allow.

Beater Moto

One, 2.0 HP.

Refrigeration System

One, 9,500 BTU/hr. R404A
 Separate Hopper Refrigeration (SHR), One, 400 BTU/hr. R134a.
 (BTUs may vary depending on compressor used.)

Air Cooled

Minimum 3" (76 mm) around all sides. Install the deflector provided to prevent recirculation of warm air. Minimum air clearances must be met to assure adequate air flow for optimum performance.

Water Cooled

Water inlet and drain connections under side of base 3/8" FPT.

Options

- Cone Dispenser
- Faucet
- Panel Spinner
- Syrup Rail Kit (side mount)

Continuing research results in steady improvements; therefore, these specifications are subject to change without notice.



Taylor Company,
 Rockton, Illinois 61072
 815-624-8333 800-255-0626 Fax 815-624-8000
 www.taylor-company.com