



TAYLOR® COMPANY
a Specialty Equipment company

Item No. _____

14

Gas Grill

14

Features

Four independent cooking zones operate with consistent temperatures and energy efficiency. Each cooking zone recovers within seconds of removing the cooked foods. Hardened steel cooking surface maintains surface flatness and resists scratches and grooves.

Cooking Zones

Four zones, with one burner each. Infrared ceramic burners offer fast, efficient recovery. Temperatures of each zone within 15°F (8°C) of set point.

Electronic Ignition

Electronic spark ignition eliminates the need for a pilot flame and ensures automatic safety lockout. High temperature ceramic insulated spark electrodes for extended life.

Main Controls

Main on/off switch, circuit breaker and temperature controls are found behind the lower front panel, protecting the controls from contaminants and abuse.

Temperature Controls

Four separate cooking zones with individual temperature controls. Each control may be set from 0 to 500°F (0 to 260°C) for menu items that require varied temperatures.

Indicator Lights

Lights are on when grill is heating to temperature. Lights turn off when set temperature has been reached. Green lights indicate lack of air pressure for ignition and shuts off gas supply.



Standard 4



Selected 50
Hz. Models

Rockton, Illinois 61072
800-255-0626
Phone 815-624-8333 Fax 815-624-8000
www.taylor-company.com
e-mail: info@taylor-company.com

International Office
Taylor Company S.r.l.
Roma, Italy
Tel: +39-06-420-12002 Fax: +39-06-420-12034
e-mail: romeoff@taylor-company.com



14 Gas Grill

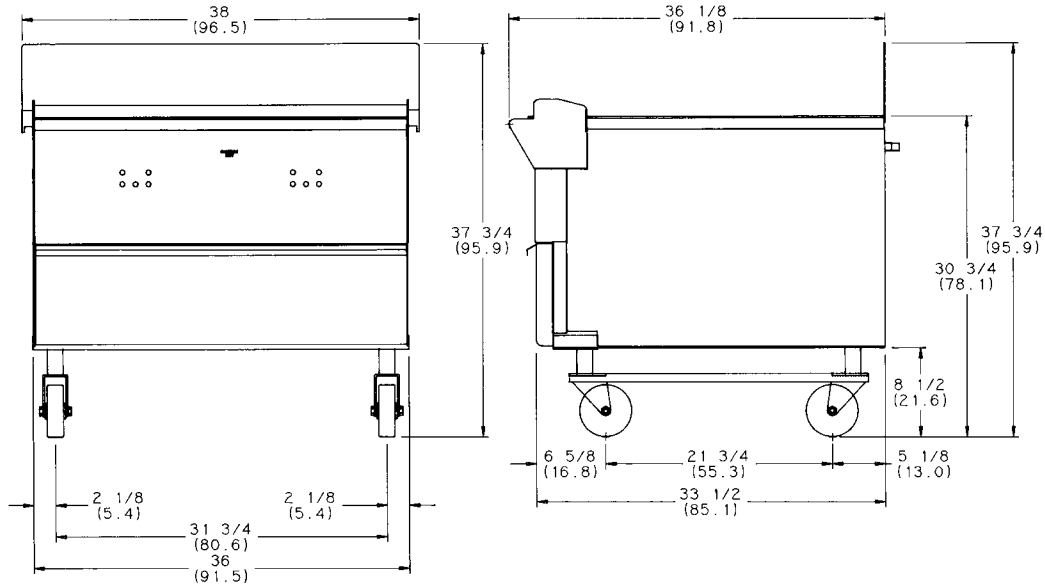

(Figures in parentheses indicate centimeters)

Weights	lbs.	kgs.
Net	560	253.9
Crated	670	303.9
	cu. ft.	cu. m.
Volume	45.8	1.3

Dimensions	in.	cm.
Width	38	96.5
Depth	36-1/8	96.5
Height	37-3/4	95.9
Floor Clearance*	2	5.1

Add to width to accommodate grease trays

Electrical	Total Amps	Recommended Circuit Size
120/60/1	3.0	20 Amp
220/50/1	2.0	20 Amp

This unit may be manufactured in other electrical characteristics. Refer to the Distributor Data Book for availability. (For exact electrical information, always refer to the data label of the unit.)

Specifications

Electrical

Requires one dedicated electrical connection. See electrical chart for complete electrical information.
(For exact electrical information, always refer to the data label of the unit.)

Gas

Four burners, 22,500 BTU/hr each; 90,000 total BTU/hr.
Manifold pressure: 5" W.C. natural gas, 10" W.C. propane.

Bidding Specs

Electrical: Volt _____ Hz _____ ph _____
Neutral: Yes No | Cooling: Air Water NA

Options: _____