

432

Frozen Beverage Freezer

Two Flavors

Features

Vary your menu by offering shakes & smoothies or frozen cocktails, fruit juices, coffees, cappuccino and tea slush beverages, all served at the desired thickness.

Freezing Cylinder

Two, 4 quart (3.8 liter).

Mix Hopper

Two, 12 quart (11.4 liter). Refrigerated to maintain mix below 41°F (5°C). Approved for dairy and non-dairy products.

Indicator Lights

Add Mix light alerts the operator to add mix. When the Mix Out light flashes, the unit automatically shuts down to prevent damage.

Automatic Consistency Control

A specially designed viscosity control automatically maintains superior product quality. An adjustable control allows the operator to serve a wide variety of frozen beverages at the desired thickness.

Lighted Display

Self-merchandising lighted display backlights the static cling flavor card and downlights the dispensing door. Five static clings are provided: Frozen Cappuccino, Frozen Cocktails, Frozen Drinks, Shakes, and Smoothies.



Shown with optional top air discharge chute



432 Frozen Beverage Freezer

Shown with optional top air discharge chute

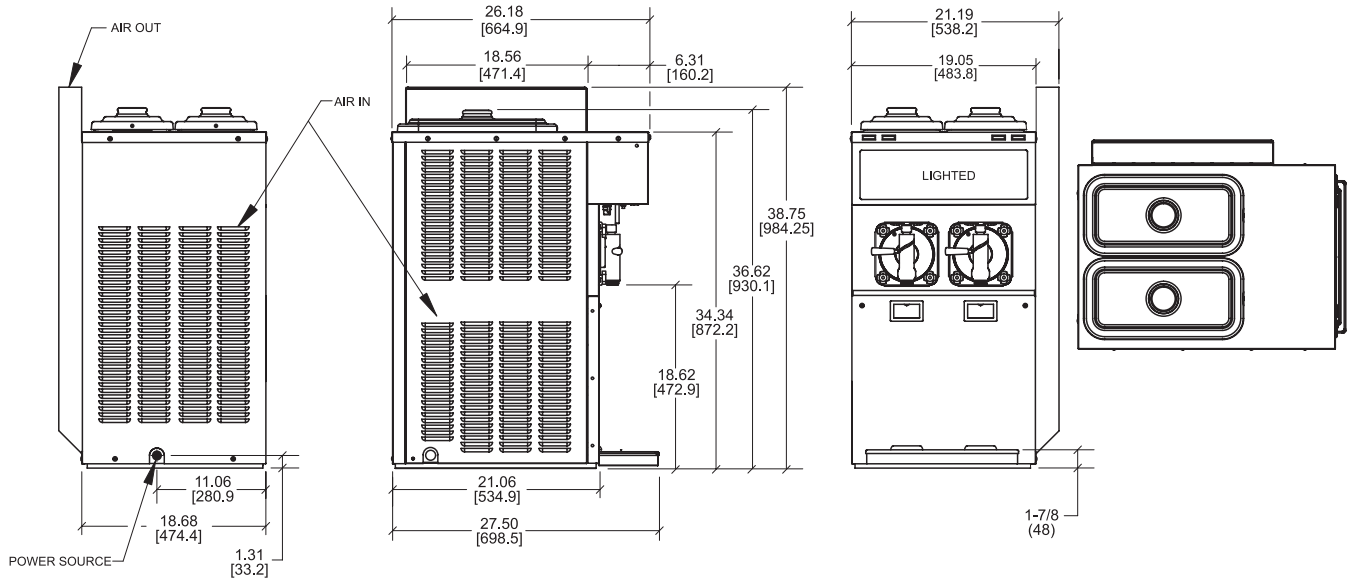

NOTE: FIGURES IN PARENTHESES INDICATE MILLIMETERS. / ALL DIMENSIONS PLUS OR MINUS 1/16 inch [1.5mm].

Weights	lbs.	kgs.
Net	305	138.3
Crated	358	162.4
	cu. ft.	cu. m.
Volume	32.7	0.93
Dimensions	in.	mm.
Width	19-1/16	484
Depth	27-1/2	699
Height	36-5/8	930
Counter Clearance	----	----

Designed to rest on a plastic pad directly on counter top or optional cart.

Electrical	Maximum Fuse Size	Minimum Circuit Ampacity	Poles (P) Wires (W)
208-230/60/1 Air	20	17	2P 3W
208-230/60/3 Air	15	13	3P 4W
220-240/50/1 Air	15	13	2P 3W
380-415/50/3N~ Air	10	9	4P 5W

This unit may be manufactured in other electrical characteristics. Refer to the local Taylor Distributor for availability.

(For exact electrical information, always refer to the data label of the unit.)

Bidding Specs

Electrical: Volt _____ Hz _____ ph _____
 Neutral: Yes No **Cooling:** Air Water NA

Options: _____

Specifications

Electrical

One dedicated electrical connection is required. See the Electrical chart for the proper electrical requirements. Manufactured to be permanently connected. Consult your local Taylor distributor for cord & receptacle specifications as local codes allow.

Refrigeration System

One, approximately 7,500 BTU/hr compressor. R404A. (BTUs may vary depending on compressor used.)

Beater Motor

Two, 1/4 HP.

Air Cooled

Minimum Clearance: 6" (152 mm) on both sides. It is recommended to place the rear of the unit against the wall. Minimum air clearances must be met to assure adequate air flow for optimum performance.

Options

- Air Discharge Chute - Minimum air clearance 3" (7.6 cm) on left side. No clearance required on right side and rear.
- Panel Spinner
- Cart with casters

C206 Cart Weights (C20600-WKP):

Net: 74 lbs. (33.6 kg) Crated: 105 lbs. (47.6 kg) 14.1 cu. ft. (0.40 cu. m.)

C206 Short Cart Weights (C20600-WKQ):

Net: 74 lbs. (33.6 kg) Crated: 105 lbs. (47.6 kg) 14.1 cu. ft. (0.40 cu. m.)

Continuing research results in steady improvements; therefore, these specifications are subject to change without notice.



Taylor Company,
 Rockton, Illinois 61072
 815-624-8333 **800-255-0626** Fax 815-624-8000
www.taylor-company.com